



Treaty Series No. 14 (1998)

1983 Amendments

to the

International Convention for the Safety of Life at Sea, 1974 (MSC.6(48)) Volume 1

Adopted London, 17 June 1983

[The Amendments entered into force on 1 July 1986]

*Presented to Parliament
by the Secretary of State for Foreign and Commonwealth Affairs
by Command of Her Majesty
April 1998*



Treaty Series No. 14 (1998)

1983 Amendments

to the

International Convention for the Safety of Life at Sea, 1974 (MSC.6(48)) Volume 1

Adopted London, 17 June 1983

[The Amendments entered into force on 1 July 1986]

*Presented to Parliament
by the Secretary of State for Foreign and Commonwealth Affairs
by Command of Her Majesty
April 1998*

RESOLUTION MSC.6(48)

adopted on 17 June 1983

**ADOPTION OF AMENDMENTS TO THE
INTERNATIONAL CONVENTION FOR THE SAFETY OF LIFE AT
SEA, 1974**

THE MARITIME SAFETY COMMITTEE,

NOTING article VIII(b) of the International Convention for the Safety of Life at Sea, 1974, hereafter referred to as "the Convention", concerning the procedure for amending the Annex to the Convention, other than the provisions of chapter I thereof,

NOTING FURTHER the functions which the Convention confers upon the Maritime Safety Committee for the consideration and adoption of amendments to the Convention,

HAVING CONSIDERED at its forty-eighth session amendments to the Convention proposed and circulated in accordance with article VIII(b)(i) thereof,

1 **ADOPTS** in accordance with article VIII(b)(iv) of the Convention amendments to chapters II-1, 11-2, III, IV and VII of the Convention, the texts of which are given in the Annex to the present resolution;

2 **DETERMINES** in accordance with article VIII(b)(vi)(2)(bb) of the Convention that the amendments to chapters II-1, 11-2, III, IV and VII shall be deemed to have been accepted on 1 January 1986 unless prior to this date more than one third of Contracting Governments to the Convention or Contracting Governments the combined merchant fleets of which constitute not less than 50 % of the gross tonnage of the world's merchant fleet, have notified their objections to the amendments;

3 **INVITES** Contracting Governments to note that in accordance with article VIII(b)(vii)(2) of the Convention the amendments to chapters II-1, 11-2, III, IV and VII shall enter into force on 1 July 1986 upon their acceptance in accordance with paragraph 2 above;

4 **REQUESTS** the Secretary-General in conformity with article VIII(b)(v) of the Convention to transmit certified copies of the present resolution and the texts of the amendments contained in the Annex to all Contracting Governments to the International Convention for the Safety of Life at Sea, 1974;

5 **FURTHER REQUESTS** the Secretary-General to transmit copies of the resolution and its Annex to Members of the Organization which are not Contracting Governments to the Convention.

Note by the Secretariat

1. At its forty-eighth session held in June 1983, the Maritime Safety Committee adopted amendments to the International Convention for the Safety of Life at Sea, 1974 (SOLAS). Thirty-three Contracting Governments to the Convention were present at the session and all the texts of the amendments were adopted in accordance with the procedure specified in Article VIII(b)(iv).
2. The amendments adopted at the session consist of complete replacement texts of Chapters III and VII and amendments to Chapters II-1, 11-2 and IV.
3. The decimal numbering system has been used in Chapters II-1, 11-2, III and VII. Metric and Imperial units have been replaced with those of the Systéme International (SI Units), except where conventionally accepted nautical units were considered more appropriate.
4. Cross references are given in a concise form, e.g. Regulation 11-2/10.4 meaning paragraph 4 of Regulation 10 of Chapter 11-2.
5. Footnotes given throughout the Convention, as well as amendments thereto, refer to the relevant recommendations annexed to the Convention and other internationally accepted standards. The Maritime Safety Committee has emphasized that these footnotes do not form part of the Convention and are only inserted for ease of reference. The footnotes are to be altered to reflect any changes which may be made to the resolutions, recommendations or documents on which they are based. References to draft resolutions to be considered by the Assembly at its thirteenth regular session are to be replaced by the definitive numbers of the resolutions as adopted by the Assembly.

ANNEX

**1983 AMENDMENTS TO THE INTERNATIONAL CONVENTION FOR THE
SAFETY OF LIFE AT SEA, 1974**

TABLE OF CONTENTS

Part 1

Page

**CHAPTER II-1 CONSTRUCTION—SUBDIVISION AND STABILITY
MACHINERY AND ELECTRICAL INSTALLATIONS**

Amendment to Regulation 1	— Application	9
Amendment to Regulation 3	— Definitions relating to Parts C, D and E	9
Amendment to Regulation 4	— Floodable length in passenger ships	10
Amendment to Regulation 5	— Permeability in passenger ships ...	10
Amendment to Regulation 6	— Permissible length of compartments in passenger ships	10
Amendment to Regulation 41	Main source of electrical power and lighting systems	11
Amendment to Regulation 42	Emergency source of electrical power in passenger ships	11
Amendment to Regulation 43	Emergency sources of electrical power in cargo ships ...	11
Amendment to Regulation 49	Control of propulsion machinery from the navigating bridge	11

Part 2

**CHAPTER CONSTRUCTION—FIRE PROTECTION, FIRE
DETECTION AND FIRE EXTINCTION**

Amendment to Regulation 1	— Application	12
Amendment to Regulation 3	— Definitions	12
Amendment to Regulation 4	— Fire pumps, fire mains, hydrants and hoses	13
Amendment to Regulation 5	— Fixed gas fire-extinguishing systems	13
Amendment to Regulation 6	— Fire extinguishers	13
Amendment to Regulation 7	— Fire extinguishing arrangements in machinery spaces	13
Amendment to Regulation 11	Special arrangements in machinery spaces	13
Amendment to Regulation 12	Automatic sprinkler, fire detection and fire alarm systems ...	13
Amendment to Regulation 13	Fixed Fire detection and fire alarm systems	13
Amendment to Regulation 14	Fixed fire detection and fire alarm systems for periodically unattended machinery spaces ...	14
Amendment to Regulation 15	Arrangements for oil fuel, lubricating oil and other flammable oils	14
Amendment to Regulation 20	Fire control plans	14
Amendment to Regulation 26	Fire integrity of bulkheads and decks in ships carrying more than 36 passengers	14

	<i>Page</i>
Amendment to Regulation 27 — Fire integrity of bulkheads and decks in ships carrying not more than 36 passengers	14
Amendment to Regulation 32 — Ventilation systems	15
Replacement of Regulation 36 — Fixed fire detection and fire alarm systems, automatic sprinkler, fire detection and fire alarm systems	15
Amendment to Regulation 37 — Protection of special category spaces	15
Amendment to Regulation 40 — Fire patrols, detection, alarms and public address systems	16
Amendment to Regulation 42 — Structure	16
Amendment to Regulation 49 — Restricted use of combustible materials	16
Amendment to Regulation 51 — Arrangements for gaseous fuel for domestic purposes	16
Amendment to Regulation 52 — Fixed fire detection and fire alarm systems, automatic sprinkler, fire detection and fire alarm systems	16
Amendment to Regulation 53 — Fire protection arrangements in cargo spaces ...	17
Amendment to Regulation 54 — Special requirements for ships carrying dangerous goods	17
Amendment to Regulation 55 — Application	17
Replacement of Regulation 56 — Location and separation of spaces	17
Amendment to Regulation 58 — Fire integrity of bulkheads and decks	19
Amendment to Regulation 59 — Venting, purging, gas freeing and ventilation ...	19
Amendment to Regulation 61 — Fixed deck foam systems	20
Amendment to Regulation 62 — Inert gas systems	20

Part 3

CHAPTER III LIFE-SAVING APPLIANCES AND ARRANGEMENTS (Replacement)

PART A—GENERAL

1 Application ...	21
2 Exemptions ...	22
3 Definitions ...	22
4 Evaluation, testing and approval of life-saving appliances and arrangements	24
5 Production tests	24

PART B—SHIP REQUIREMENTS

Section 1—PASSENGER SHIPS AND CARGO SHIPS

6 Communications	25
7 Personal life-saving appliances ...	26
8 Muster list and emergency instructions	27

	<i>Page</i>
9 Operating instructions ..	27
10 Manning of survival craft and supervision	27
11 Survival craft muster and embarkation arrangements	28
12 Launching stations ...	28
13 Stowage of survival craft	28
14 Stowage of rescue boats	29
15 Survival craft launching and recovery arrangements ...	29
16 Rescue boat embarkation, launching and recovery arrangements	30
17 Line-throwing appliances	31
18 Abandon ship training and drills	31
19 Operational readiness, maintenance and inspections... ..	32
 Section II—PASSENGER SHIPS (ADDITIONAL REQUIREMENTS)	
20 Survival craft and rescue boats	34
21 Personal life-saving appliances	35
22 Survival craft and rescue boat embarkation arrangements	36
23 Stowage of liferafts	36
24 Muster stations	36
25 Drills...	37
 Section III—CARGO SHIPS (ADDITIONAL REQUIREMENTS)	
26 Survival craft and rescue boats ..	37
27 Personal life-saving appliances ..	39
28 Survival craft embarkation and launching arrangements	40
29 Stowage of liferafts	40
 PART C—LIFE-SAVING APPLIANCE REQUIREMENTS	
Section 1—GENERAL	
30 General requirements for life-saving appliances	40
 Section II—PERSONAL LIFE-SAVING APPLIANCES	
31 Lifebuoys	41
32 Lifejackets ...	42
33 Immersion suits ..	43
34 Thermal protective aids ...	44
 Section III—VISUAL SIGNALS	
35 Rocket parachute flares	44
36 Hand flares ...	45
37 Buoyant smoke signals	45
 Section IV—SURVIVAL CRAFT	
38 General requirements for liferafts	45
39 Inflatable liferafts	49
40 Rigid liferafts	51

	<i>Page</i>
41 General requirements for lifeboats	53
42 Partially enclosed lifeboats ...	59
43 Self-righting partially enclosed lifeboats ..*	59
44 Totally enclosed lifeboats ...	61
45 Lifeboats with a self-contained air support system ...	62
46 Fire-protected lifeboats	62
 Section V—RESCUE BOATS	
47 Rescue boats ...	63
 Section VI—LAUNCHING AND EMBARKATION APPLIANCES	
48 Launching and embarkation appliances ...	65
 Section VII—OTHER LIFE-SAVING APPLIANCES	
49 Line-throwing appliances	68
50 General emergency alarm system ...	68
 Section VIII—MISCELLANEOUS	
51 Training manual ...	68
52 Instructions for on-board maintenance	69
53 Muster list and emergency instructions	69

Part 4

CHAPTER IV—RADIOTELEGRAPHY AND RADIOTELEPHONY

Amendment to Regulation 2 — Terms and definitions	71
Addition of new Regulation 14-1 — Survival craft emergency position indicating radio beacons	71
Addition of new Regulation 14-2 — Periodic inspection and testing of emergency position-indicating radio beacons	71
Addition of new Regulation 14-3 — Two-way radiotelephone apparatus for survival craft ...	72

Part 5

CHAPTER VII—CARRIAGE OF DANGEROUS GOODS (Replacement)

PART A—CARRIAGE OF DANGEROUS GOODS IN PACKAGED FORM OR IN SOLID FORM IN BULK

1 Application ...	73
2 Classification ...	73
3 Packaging ...	74
4 Marking, labelling and placarding	74
5 Documents	75
6 Stowage requirements ...	75
7 Explosives in passenger ships ...	75

	<i>Page</i>
PART B—CONSTRUCTION AND EQUIPMENT OF SHIPS CARRYING DANGEROUS LIQUID CHEMICALS IN BULK	
8 Definitions	76
9 Application to chemical tankers	76
10 Requirements for chemical tankers ...	77
 PART C—CONSTRUCTION AND EQUIPMENT OF SHIPS CARRYING LIQUEFIED GASES IN BULK	
11 Definitions ...	77
12 Application to gas carriers	77
13 Requirements for gas carriers	78

Part 1

CHAPTER II-1

**CONSTRUCTION—SUBDIVISION AND STABILITY,
MACHINERY AND ELECTRICAL INSTALLATIONS**

Chapter II-1 of the Convention is replaced by the text of chapter II-1 annexed to resolution MSC. 1 (XLV), further amended as follows:

Regulation 1

Application

In paragraph 1.1 line 3 delete "1 September 1984" and insert "1 July 1986".

In paragraph 1.3.2 line 2 delete "1 September 1984" and insert "1 July 1986".

Replace the whole of paragraph 2 by:

"Unless expressly provided otherwise, for ships constructed before 1 July 1986 the Administration shall ensure that the requirements which are applicable under chapter II-1 of the International Convention for the Safety of Life at Sea, 1974, as amended by resolution MSC.1(XLV), are complied with."

Delete the footnote.

In paragraph 3 lines 4 and 9 delete "1 September 1984" and insert "1 July 1986".

Delete paragraph 5 and renumber paragraph 6 as paragraph 5.

Regulation 3

Definitions relating to Parts C, D and E

In paragraph 18 delete "fire" and insert "fire".

Amend paragraph 19 as follows:

"'Chemical tanker' is a cargo ship constructed or adapted and used for the carriage in bulk of any liquid product listed in either:

- .1 chapter 17 of the International Code for the Construction and Equipment of Ships Carrying Dangerous Chemicals in Bulk adopted by the Maritime Safety Committee by resolution MSC.4(48), hereinafter referred to as 'the International Bulk Chemical Code', as may be amended by the Organization; or

- .2 chapter VI of the Code for the Construction and Equipment of Ships Carrying Dangerous Chemicals in Bulk adopted by the Assembly of the Organization by resolution A.212(VII), hereinafter referred to as 'the Bulk Chemical Code', as has been or may be amended by the Organization;

whichever is applicable."

Amend paragraph 20 to read:

'Gas carrier' is a cargo ship constructed or adapted and used for the carriage in bulk of any liquefied gas or other products listed in either:

- .1 chapter 19 of the International Code for the Construction and Equipment of Ships Carrying Liquefied Gases in Bulk adopted by the Maritime Safety Committee by resolution MSC.5(48) hereinafter referred to as 'the International Gas Carrier Code', as may be amended by the Organization; or
- .2 chapter XIX of the Code for the Construction and Equipment of Ships Carrying Liquefied Gases in Bulk adopted by the Assembly of the Organization by resolution A.328(IX), hereinafter referred to as 'the Gas Carrier Code', as has been or may be amended by the Organization;

whichever is applicable."

Regulation 4

Floodable length in passenger ships

Paragraph 1, line 3 delete "andd" and insert "and".

Regulation 5

Permeability in passenger ships

Amend paragraph 4.1 to read:

"4.1 In the case of special subdivision required in regulation 6.5, the uniform average permeability throughout the portion of the ship forward of or abaft the machinery space shall be $95-35 \text{ b/v}$ where:

- b = the volume of the spaces below the margin line and above the tops of floors, inner bottom, or peak tanks, as the case may be, which are appropriated to and used as cargo spaces, coal or oil fuel bunkers, store-rooms, baggage and mail rooms, chain lockers and fresh water tanks, forward of or abaft the machinery space; and
- v = the whole volume of the portion of the ship below the margin line forward of or abaft the machinery space."

Regulation 6

Permissible length of compartments in passenger ships

Paragraph 2.2, line 2 delete "seervice" and insert "service".

Replace the heading of section 5 by "Special subdivision standards for ships complying with regulation III/20.1.2."

Insert new paragraphs 5.3 and 5.4 as follows:

"5.3 The special provisions regarding permeability given in regulation 5.4 shall be employed when calculating the floodable length curves.

5.4 Where the Administration is satisfied that, having regard to the nature and conditions of the intended voyages compliance with the other provisions of this chapter and of chapter 11-2 is sufficient, the requirements of this paragraph need not be complied with."

Regulation 41

Main source of electrical power and lighting systems

Paragraph 1.3, line 3 insert "of rotation" after "direction".

Regulation 42

Emergency source of electrical power in passenger ships

Amend sub-paragraph 2.1.1 to read:

".1 at every muster and embarkation station and over the sides as required by regulations 111/1 1.4 and 111/15.7".

Insert new sub-paragraph 2.1.2 to read:

".2 in alleyways, stairways and exits giving access to the muster and embarkation stations, as required by regulation 111 1.5".

Renumber sub-paragraphs 2.1.2 to 2.1.7 to read 2.1.3 to 2.1.8.

Paragraph 2.3.4, line 2 delete "manual fire alarms" and insert "manually operated call points".

Regulation 43

Emergency source of electrical power in cargo ships

Paragraph 1.3, line 10 delete "sppace" and insert "space".

Amend paragraph 2.1 to read:

"2.1 For a period of 3 h, emergency lighting at every muster and embarkation station and over the sides as required by regulations 111/1 1.4 and 111/1 5.7."

Paragraph 2.4.4, line 2 delete "manual fire alarms" and insert "manually operated call points".

Regulation 49

Control of propulsion machinery from the navigating bridge

Paragraph 3, line 6

delete "the machinery space" and insert "the main machinery space"

delete "the machinery control room" and insert "the main machinery control room".

Paragraph 5, line 3

insert "of the propeller" after "thrust".

Paragraph 6.1, line 1

delete "in case" and insert "in the case".

Paragraph 6.2, line 1

delete "in case" and insert "in the case".

Part 2

CHAPTER 11-2

CONSTRUCTION—FIRE PROTECTION, FIRE DETECTION AND FIRE EXTINCTION

Chapter 11-2 of the Convention is replaced by the text of chapter 11-2 annexed to resolution MSC.1(XLV), further amended as follows:

Regulation 1

Application

In paragraph 1.1 line 3 delete "1 September 1984" and insert "1 July 1986"

In paragraph 1.3.2 line 2 delete "1 September 1984" and insert "1 July 1986".

Replace the whole of paragraph 2 by:

"Unless expressly provided otherwise, for ships constructed before 1 July 1986 the Administration shall ensure that the requirements which are applicable under chapter 11-2 of the International Convention for the Safety of Life at Sea, 1974, as amended by resolution MSC.1(XLV), are complied with."

In paragraph 3 lines 4 and 9 delete "1 September 1984" and insert "1 July 1986".

Delete the footnote.

Regulation 3

Definitions

In paragraph 12 correct "main and specie rooms" to read "mail and specie rooms".

Paragraph 30, amend to:

"'Chemical tanker' is a tanker constructed or adapted and used for the carriage in bulk of any liquid product of a flammable nature listed in either:

- .1 chapter 17 of the International Code for the Construction and Equipment of Ships Carrying Dangerous Chemicals in Bulk adopted by the Maritime Safety Committee by resolution MSC.4 (48), hereinafter referred to as 'the International Bulk Chemical Code', as may be amended by the Organization; or
- .2 chapter VI of the Code for the Construction and Equipment of Ships Carrying Dangerous Chemicals in Bulk adopted by the Assembly of the Organization by resolution A.212(VII), hereinafter referred to as 'the Bulk Chemical Code', as has been or may be amended by the Organization;

whichever is applicable."

Paragraph 31 amend to:

"'Gas carrier' is a tanker constructed or adapted and used for the carriage in bulk of any liquefied gas or other products of a flammable nature listed in either:

- .1 chapter 19 of the International Code for the Construction and Equipment of Ships Carrying Liquefied Gases in Bulk adopted by the Maritime Safety Committee by resolution MSC.5(48), hereinafter referred to as 'the International Gas Carrier Code', as may be amended by the Organization;
- or

.2 chapter XIX of the Code for the Construction and Equipment of Ships Carrying Liquefied Gases in Bulk adopted by the Assembly of the Organization by resolution A.328(IX), hereinafter referred to as 'the Gas Carrier Code', as has been or may be amended by the Organization;

whichever is applicable."

Add an additional paragraph to read:

"32 'Cargo area' is that part of the ship that contains cargo tanks, slop tanks and cargo pump rooms including pump rooms, cofferdams, ballast and void spaces adjacent to cargo tanks and also deck areas throughout the entire length and breadth of the part of the ship over the above-mentioned spaces."

Regulation 4

Fire pumps, fire mains, hydrants and hoses

In paragraph 3.3.2.6 line 3 delete "room" and insert "station".

Regulation 5

Fixed gas fire-extinguishing systems

In paragraph 2.2 line 2 delete "quantity" and insert "volume".

In paragraph 2.2 line 3 delete "quantities" and insert "volumes".

Regulation 6

Fire extinguishers

In paragraph 7 line 2 delete "provideed" and insert "provided".

Regulation 7

Fire-extinguishing arrangements in machinery spaces

In paragraph 1.2 line 1 and 2 delete "air foam equipment" and insert "foam applicator unit".

Regulation 11

Special arrangements in machinery spaces

In the first line of paragraph 8 amend "An approved automatic fire detection and alarm system" to read "A fixed fire detection and alarm system".

Regulation 12

Automatic sprinkler, fire detection and fire alarm systems

In paragraph 3 correct "sppaced" to read "spaced".

Regulation 13

Fixed fire detection and fire alarm systems

In paragraph 2.1 lines 1, 2, 3 and 5 delete "Manual" and insert "Manually operated".

Regulation 14

Fixed fire detection and fire alarm systems for periodically unattended machinery spaces

In paragraph 1, line 1 amend to read "A fixed fire detection and fire alarm system of an approved type in accordance with the".

Regulation 15

Arrangements for oil fuel, lubricating oil and other flammable oils

Insert a new paragraph 6 to read:

"6 Prohibition of carriage of flammable oils in forepeak tanks

Oil fuel, lubricating oil and other flammable oils shall not be carried in forepeak tanks".

Regulation 20

Fire control plans

Paragraph 1, lines 14 and 15 delete "national language" and insert "official language of the flag State".

Regulation 26

Fire integrity of bulkheads and decks in ships carrying more than 36 passengers

Paragraph 2.2, line 1 delete "for the purpose of" and insert "For".

line 10 delete "number".

*Paragraph 2.2(1), line 4 **delete** "fire control and recording stations" and insert "fire control rooms and fire-recording stations".*

Paragraph 2.2(5), line 3 delete "Air space" and insert "Air spaces".

Table 26.2, line 5 delete "space" and insert "spaces".

Regulation 27

Fire integrity of bulkheads and decks in ships carrying not more than 36 passengers

Paragraph 2.2(1), line 4 delete "stations" and insert "rooms".

*In Table 27.1, **line 2, column 4***

line 3, column 4

line 4, column 4

line 4, column 5

replace B-O^{el} by A-Oal

A-O^{al} B-Oel

Paragraph 4, line 4 delete "this chapter" and insert "this part".

Regulation 32

Ventilation systems

Paragraph 1.4.3.1, line 1 delete "restricted" and insert "low".

Replace Regulation 36 by:

"Regulation 36

Fixed fire detection and fire alarm systems

Automatic sprinkler, fire detection and fire alarm systems

In any ship to which this part applies, there shall be installed throughout each separate zone, whether vertical or horizontal, in all accommodation and service spaces and, where it is considered necessary by the Administration, in control stations, except spaces which afford no substantial fire risk such as void spaces, sanitary spaces, etc., either:

- .1 a fixed fire detection and fire alarm system of an approved type and complying with the requirements of regulation 13 and so installed and arranged as to detect the presence of fire in such spaces; or
- .2 an automatic sprinkler, fire detection and fire alarm system of an approved type and complying with the requirements of regulation 12 and so installed and arranged as to protect such spaces and in addition a fixed fire detection and fire alarm system of an approved type complying with the requirements of regulation 13 so installed and arranged as to provide smoke detection in corridors, stairways and escape routes within accommodation spaces."

Regulation 37

Protection of special category spaces

Amend the text of paragraph 1.4.1 to read:

"1.4.1 An efficient patrol system shall be maintained in special category spaces. In any such space in which the patrol is not maintained by a continuous fire watch at all times during the voyage there shall be provided a fixed fire detection and fire alarm system of an approved type complying with the requirements of regulation 13. The fixed fire detection system shall be capable of rapidly detecting the onset of fire. The spacing and location of detectors shall be tested to the satisfaction of the Administration taking into account the effects of ventilation and other relevant factors."

Amend the text of paragraph 2.2.1 to read:

"2.2.1 On any deck or platform, if fitted, on which vehicles are carried and on which explosive vapours might be expected to accumulate, except platforms with openings of sufficient size permitting penetration of petrol gases downwards, equipment which may constitute a source of ignition of flammable vapours and, in particular, electrical equipment and wiring, shall be installed at least 450 mm above the deck or platform. Electrical equipment installed at more than 450 mm above the deck or platform shall be of a type so enclosed and protected as to prevent the escape of sparks. However, if the Administration is satisfied that the installation of electrical equipment and wiring at less than 450 mm above the deck or platform is necessary for the safe operation of the ship, such electrical equipment and wiring may be installed provided that it is of a type approved for use in an explosive petrol and air mixture."

Regulation 40

Fire patrols, detection, alarms and public address systems

Amend paragraphs 1 and 2 to read:

"1 Manually operated call points complying with the requirements of regulation 13 shall be installed".

"2 A fixed fire detection and fire alarm system of an approved type shall be provided".

Regulation 42

Structure

In paragraph 1, second line, amend "deck" to read "decks".

Regulation 49

Restricted use of combustible materials

Amend the text of paragraph 3 to read:

"Primary deck coverings, if applied within accommodation and service spaces and control stations, shall be of approved material which will not readily ignite, or give rise to toxic or explosive hazards at elevated temperatures.**"

Regulation 51

Arrangements for gaseous fuel for domestic purposes

Delete comma and insert "for the" after "arrangements".

Regulation 52

Fixed fire detection and fire alarm systems

Automatic sprinkler, fire detection and fire alarm systems

Amend the first three paragraphs to read:

"1 In ships in which method IC is adopted, a fixed fire detection and fire alarm system of an approved type complying with the requirements of regulation 13 shall be so installed and arranged as to provide smoke detection and manually operated call points in all corridors, stairways and escape routes within accommodation spaces.

2 In ships in which method IIC is adopted, an automatic sprinkler, fire detection and fire alarm system of an approved type complying with the relevant requirements of regulation 12 shall be so installed and arranged as to protect accommodation spaces, galleys and other service spaces, except spaces which afford no substantial fire risk such as void spaces, sanitary spaces, etc. In addition, a fixed fire detection and fire alarm system of an approved type complying with the requirements of regulation 13 shall be so installed and arranged as to provide smoke detection and manually operated call points in all corridors, stairways and escape routes within accommodation spaces.

3 In ships in which method IIIC is adopted, a fixed fire detection and fire alarm system of an approved type complying with the requirements of regulation 13 shall be so installed and arranged as to detect the presence of fire in all accommodation spaces and service spaces, except spaces which afford no substantial fire risk such as void spaces, sanitary spaces, etc."

Delete paragraph 4.

Regulation 53

Fire protection arrangements in cargo spaces

In paragraph 1.3, line 4, delete "by" and insert "with".

Amend the first sentence of paragraph 2.1 to read: "There shall be provided a fixed fire detection and fire alarm system of an approved type."

Replace paragraph 2.4.2 by the following:

"2 Above a height of 450 mm from the deck and from each platform for vehicles, if fitted, except platforms with openings of sufficient size permitting penetration of petrol gases downwards, electrical equipment of a type so enclosed and protected as to prevent the escape of sparks shall be permitted as an alternative on condition that the ventilating system is so designed and operated as to provide continuous ventilation of the cargo spaces at the rate of at least 10 air changes per hour whenever vehicles are on board."

Regulation 54

Special requirements for ships carrying dangerous goods

In table 54.2, note f amend "...in addition to those enumerated..." to read "...in addition to meeting the requirements enumerated..."

Amend the first sentence in paragraph 2.3 to read: "A fixed fire detection and fire alarm system of an approved type shall be fitted to all enclosed cargo spaces including closed vehicle deck spaces."

Regulation 55

Application

Amend paragraph 2 to read:

"Where liquid cargoes other than those referred to in paragraph 1 or liquefied gases which introduce additional fire hazards are intended to be carried, additional safety measures shall be required to the satisfaction of the Administration, having due regard to the provisions of the International Bulk Chemical Code, the Bulk Chemical Code, the International Gas Carrier Code and the Gas Carrier Code, as appropriate."

Amend paragraph 6 to read:

"Chemical tankers and gas carriers shall comply with the requirements of this part, except where alternative and supplementary arrangements are provided to the satisfaction of the Administration, having due regard to the provisions of the International Bulk Chemical Code, the Bulk Chemical Code, the International Gas Carrier Code and the Gas Carrier Code, as appropriate."

Regulation 56

Location and separation of spaces

Replace the text of the whole regulation by:

"1 Machinery spaces shall be positioned aft of cargo tanks and slop tanks; they shall also be situated aft of cargo pump rooms and cofferdams, but not necessarily aft of the oil fuel bunker tanks. Any machinery space shall be isolated from cargo tanks and slop tanks by cofferdams, cargo pump rooms, oil fuel bunker tanks or permanent ballast tanks. Pump rooms containing pumps and their accessories for ballasting those spaces situated adjacent to cargo tanks and slop tanks and pumps for oil fuel transfer shall be considered as equivalent to a cargo pump room within the context of this regulation, provided that such pump rooms have the same safety standard as that required for cargo pump rooms. However, the lower portion of the pump room may be recessed into machinery spaces of category A to accommodate pumps, provided that the deck head of the recess is in general

not more than one third of the moulded depth above the keel, except that in the case of ships of not more than 25,000 tonnes deadweight, where it can be demonstrated that for reasons of access and satisfactory piping arrangements this is impracticable, the Administration may permit a recess in excess of such height, but not exceeding one half of the moulded depth above the keel.

2 Accommodation spaces, main cargo control stations, control stations and service spaces (excluding isolated cargo handling gear lockers) shall be positioned aft of all cargo tanks, slop tanks, cargo pump rooms and cofferdams which isolate cargo or slop tanks from machinery spaces but not necessarily aft of the oil fuel bunker tanks. A recess provided in accordance with paragraph 1 need not be taken into account when the position of these spaces is being determined.

3 However, where deemed necessary, accommodation spaces, control stations, machinery spaces other than those of category A, and service spaces may be permitted forward of the cargo area, provided they are isolated from the cargo tanks and slop tanks by cofferdams, cargo pump rooms, oil fuel bunker tanks or permanent ballast tanks and subject to an equivalent standard of safety and appropriate availability of fire-extinguishing arrangements being provided to the satisfaction of the Administration. In addition, where deemed necessary for the safety or navigation of the ship, the Administration may permit machinery spaces containing internal combustion machinery not being main propulsion machinery having an output greater than 375 kW to be located forward of the cargo area provided the arrangements are in accordance with the provisions of this paragraph.

4 In combination carriers only:

- .1 The slop tanks are to be surrounded by cofferdams except where the boundaries of the slop tanks where slop may be carried on dry cargo voyages are the hull, main cargo deck, cargo pump room bulkhead or oil fuel bunker tank. These cofferdams shall not be open to a double bottom, pipe tunnel, pump room or other enclosed space. Means shall be provided for filling the cofferdams with water and for draining them. Where the boundary of a slop tank is the cargo pump room bulkhead the pump room shall not be open to the double bottom, pipe tunnel or other enclosed space, however, openings provided with gastight bolted covers may be permitted.
- .2 Means shall be provided for isolating the piping connecting the pump room with the slop tanks referred to in paragraph 4.1. The means of isolation shall consist of a valve followed by a spectacle flange or a spool piece with appropriate blank flanges. This arrangement shall be located adjacent to the slop tanks, but where this is unreasonable or impracticable it may be located within the pump room directly after the piping penetrates the bulkhead. A separate pumping and piping arrangement shall be provided for discharging the contents of the slop tanks directly over the open deck when the ship is in the dry cargo mode.
- .3 Hatches and tank cleaning openings to slop tanks shall only be permitted on the open deck and shall be fitted with closing arrangements. Except where they consist of bolted plates with bolts at watertight spacing, these closing arrangements shall be provided with locking arrangements which shall be under the control of the responsible ship's officer.
- .4 Where cargo wing tanks are provided, cargo oil lines below deck shall be installed inside these tanks. However, the Administration may permit cargo oil lines to be placed in special ducts which shall be capable of being adequately cleaned and ventilated and be to the satisfaction of the Administration. Where cargo wing tanks are not provided cargo oil lines below deck shall be placed in special ducts.

5 Where the fitting of a navigation position above the cargo area is shown to be necessary, it shall be for navigation purposes only and it shall be separated from the cargo tank deck by means of an open space with a height of at least 2 m. The fire protection of such a navigation position shall in addition be as required for control spaces in regulation 58.1 and 58.2 and other provisions, as applicable, of this part.

6 Means shall be provided to keep deck spills away from the accommodation and service areas. This may be accomplished by provision of a permanent continuous coaming of a suitable height extending from side to side. Special consideration shall be given to the arrangements associated with stern loading.

7 Exterior boundaries of superstructures and deckhouses enclosing accommodation and including any overhanging decks which support such accommodation, shall be insulated to `A-60' standard for the whole of the portions which face the cargo area and for 3 m aft of the front boundary. In the case of the sides of those superstructures and deckhouses, such insulation shall be carried as high as is deemed necessary by the Administration.

8.1 Entrances, air inlets and openings to accommodation spaces, service spaces and control stations shall not face the cargo area. They shall be located on the transverse bulkhead not facing the cargo area or on the outboard side of the superstructure or deckhouse at a distance of at least 4% of the length of the ship but not less than 3 m from the end of the superstructure or deckhouse facing the cargo area. This distance, however, need not exceed 5 m.

8.2 No doors shall be fitted within the limits specified in paragraph 8.1 except that doors to spaces not having access to accommodation spaces, service spaces and control stations may be permitted by the Administration. Such spaces may be cargo control stations, provision rooms and store-rooms. Where such doors are fitted to spaces located aft of the cargo area, the boundaries of the space shall be insulated to `A-60' standard, with the exception of the boundary facing the cargo area. Bolted plates for removal of machinery may be fitted within the limits specified in paragraph 8.1. Wheelhouse doors and wheelhouse windows may be located within the limits specified in paragraph 8.1 so long as they are designed to ensure that the wheelhouse can be made rapidly and efficiently gas and vapour tight.

8.3 Windows and sidescuttles facing the cargo area and on the sides of the superstructures and deckhouses within the limits specified in paragraph 8.1 shall be of the fixed (non-opening) type. Such windows and sidescuttles in the first tier on the main deck shall be fitted with inside covers of steel or other equivalent material."

Regulation 58

Fire integrity of bulkheads and decks

In table 1, note 1/2, line 1 — delete "b" and insert "121".

Paragraph 4, line 4—delete "these Requirements" and insert "this part"

Regulation 59

Venting, purging, gas freeing and ventilation

Paragraph 2, line 16 delete "gas" and insert "vapour".

line 18 delete "gas" and insert "vapour".

lines 16, 17 and 18 "When . . . level." forms part of paragraph 2 and must be moved to that paragraph's margin.

Amend paragraph 3.3 as follows:

In the third sentence amend "referred to in Regulation 56.1" to read "referred to in regulation 56.4."

In the fourth sentence amend "cargo tank area" to read "cargo area".

Regulation 61

Fixed deck foam systems

In paragraph 1 amend "cargo tank area" to read "cargo tanks deck area".

In paragraph 2 amend "cargo tank area" to read "cargo area" in the second sentence.

In paragraph 3.1 amend "cargo deck area" to read "cargo tanks deck area".

In paragraph 7 in the first and second sentence amend "cargo deck" to read "cargo tank deck".

In paragraph 8, third line, amend "400 litres" to read "400 litres/min". In the fourth sentence amend "any cargo tank deck area" to read "any part of the cargo tanks deck area".

Regulation 62

Inert gas systems

In paragraph 1 delete "non flammable" and insert "non flammable".

In paragraph 9.1, lines 2 and 3 delete "19.2" and "19.3" and insert "19.3" and "19.4" respectively.

In paragraph 10.2 amend "cargo tank area" to read "cargo area".

Replace paragraph 14.1 by:

"14.1 One or more pressure vacuum breaking devices shall be provided to prevent the cargo tanks from being subject to:

- .1 a positive pressure in excess of the test pressure of the cargo tank if the cargo were to be loaded at the maximum rated capacity and all other outlets are left shut; and
- .2 a negative pressure in excess of 700 mm water gauge if cargo were to be discharged at the maximum rated capacity of the cargo pumps and the inert gas blowers were to fail.

Such devices shall be installed on the inert gas main unless they are installed in the venting system required by regulation 59.1.1 or on individual cargo tanks."

In paragraph 20.1 amend the last line to read "10.2, 10.7, 10.9, 11.3, 11.4, 12, 13.1, 13.2, 13.4.2, 14.2 and 19.8;"

In paragraph 20.2 amend the last line to read "12, 13.1, 13.2 and 14.2."

Part 3

CHAPTER III

The existing text of chapter III is replaced by the following:

LIFE-SAVING APPLIANCES AND ARRANGEMENTS

PART A—GENERAL

Regulation 1

Application

- 1 Unless expressly provided otherwise, this chapter shall apply to ships the keels of which are laid or which are at a similar stage of construction on or after 1 July 1986.
- 2 For the purpose of this chapter the term "a similar stage of construction" means the stage at which:
 - .1 construction identifiable with a specific ship begins; and
 - .2 assembly of that ship has commenced comprising at least 50 tonnes or 1% of the estimated mass of all structural material, whichever is less.
- 3 For the purpose of this chapter:
 - .1 the expression "ships constructed" means "ships the keels of which are laid or which are at a similar stage of construction";
 - .2 the expression "all ships" means "ships constructed before, on or after 1 July 1986"; the expressions "all passenger ships" and "all cargo ships" shall be construed accordingly;
 - .3 a cargo ship, whenever built, which is converted to a passenger ship shall be treated as a passenger ship constructed on the date on which such a conversion commences.
- 4 For ships constructed before 1 July 1986, the Administration shall:
 - .1 ensure that, subject to the provisions of paragraph 4.2 and 4.3, the requirements which are applicable under chapter III of the International Convention for the Safety of Life at Sea, 1974, in force prior to 1 July 1986 to new or existing ships as prescribed by that chapter are complied with;
 - .2 consider the life-saving appliances and arrangements in ships which do not comply with the requirements referred to in paragraph 4.1, with a view to securing, so far as this is reasonable and practicable and as early as possible, substantial compliance with those requirements;
 - .3 ensure that when life-saving appliances or arrangements on such ships are replaced or such ships undergo repairs, alterations or modifications of a major character which involve replacement of, or any addition to, their existing life-saving appliances or arrangements, such life-saving appliances or arrangements, in so far as is reasonable and practicable, comply with the requirements of this chapter. However, if a survival craft is replaced without replacing its launching appliance, or vice versa, the survival craft or launching appliance may be of the same type as that replaced;
 - .4 approve the life-saving appliances to be provided in compliance with paragraph 6. The Administration may permit those life-saving appliances provided on board ships prior to 1 July 1991 not to comply fully with the requirements of this chapter as long as they remain in a satisfactory condition;
 - .5 except as provided for survival craft and launching appliances referred to in paragraph 4.3, ensure that life-saving appliances replaced or installed on or after 1 July 1991 are evaluated, tested and approved in accordance with the requirements of regulations 4 and 5.

5 With respect to ships constructed before 1 July 1986 the requirements of regulations 8, 9, 10, 18 and 25 and, to the extent prescribed therein, regulation 19 shall apply.

6 With respect to ships constructed before 1 July 1986 the requirements of regulations 6.2.3, 6.2.4, 21.3, 21.4, 26.3, 27.2, 27.3 and 30.2.7 shall apply not later than 1 July 1991.

Regulation 2

Exemptions

1 The Administration may, if it considers that the sheltered nature and conditions of the voyage are such as to render the application of any specific requirements of this chapter unreasonable or unnecessary, exempt from those requirements individual ships or classes of ships which, in the course of their voyage, do not proceed more than 20 miles from the nearest land.

2 In the case of passenger ships which are employed in special trades for the carriage of large numbers of special trade passengers, such as the pilgrim trade, the Administration, if satisfied that it is impracticable to enforce compliance with the requirements of this chapter, may exempt such ships from those requirements, provided that such ships comply fully with the provisions of:

- .1 the rules annexed to the Special Trade Passenger ships Agreement, 1971; and
- .2 the rules annexed to the Protocol on Space Requirements for Special Trade Passenger Ships, 1973.

Regulation 3

Definitions

For the purpose of this chapter, unless expressly provided otherwise:

1 *Certified person* is a person who holds a certificate of proficiency in survival craft issued under the authority of, or recognized as valid by, the Administration in accordance with the requirements of the International Convention on Standards of Training, Certification and Watchkeeping for Seafarers, in force; or a person who holds a certificate issued or recognized by the Administration of a State not a Party to that Convention for the same purpose as the convention certificate.

2 *Detection* is the determination of the location of survivors or survival craft.

3 *Embarkation ladder* is the ladder provided at survival craft embarkation stations to permit safe access to survival craft after launching.

4 *Float-free launching* is that method of launching a survival craft whereby the craft is automatically released from a sinking ship and is ready for use.

5 *Free-fall launching* is that method of launching a survival craft whereby the craft with its complement of persons and equipment on board is released and allowed to fall into the sea without any restraining apparatus.

6 *Immersion suit* is a protective suit which reduces the body heat-loss of a person wearing it in cold water.

7 *Inflatable appliance* is an appliance which depends upon non-rigid, gas filled chambers for buoyancy and which is normally kept uninflated until ready for use.

8 *Inflated appliance* is an appliance which depends upon non-rigid, gas filled chambers for buoyancy and which is kept inflated and ready for use at all times.

9 *Launching appliance or arrangement* is a means of transferring a survival craft or rescue boat from its stowed position safely to the water.

10 *Length* is 96% of the total length on a waterline at 85% of the least moulded depth measured from the top of the keel, or the length from the fore-side of the stem to the axis of the rudder stock on that waterline, if that be greater. In ships designed with a rake of keel the waterline on which this is measured shall be parallel to the designed waterline.

11 *Moulded depth*

- .1 The moulded depth is the vertical distance measured from the top of the keel to the top of the freeboard deck beam at side. In wood and composite ships the distance is measured from the lower edge of the keel rabbet. Where the form at the lower part of the midship section is of a hollow character, or where thick garboards are fitted, the distance is measured from the point where the line of the flat of the bottom continued inwards cuts the side of the keel.
- .2 In ships having rounded gunwales, the moulded depth shall be measured to the point of intersection of the moulded lines of the deck and side shell plating, the lines extending as though the gunwale were of angular design.
- .3 Where the freeboard deck is stepped and the raised part of the deck extends over the point at which the moulded depth is to be determined, the moulded depth shall be measured to a line of reference extending from the lower part of the deck along a line parallel with the raised part.

12 *Novel life-saving appliance or arrangement* is a life-saving appliance or arrangement which embodies new features not fully covered by the provisions of this chapter but which provides an equal or higher standard of safety.

13 *Rescue boat* is a boat designed to rescue persons in distress and to marshal survival craft.

14 *Retrieval* is the safe recovery of survivors.

15 *Retro-reflective material* is a material which reflects in the opposite direction a beam of light directed on it.

16 *Short international voyage* is an international voyage in the course of which a ship is not more than 200 miles from a port or place in which the passengers and crew could be placed in safety. Neither the distance between the last port of call in the country in which the voyage begins and the final port of destination nor the return voyage shall exceed 600 miles. The final port of destination is the last port of call in the scheduled voyage at which the ship commences its return voyage to the country in which the voyage began.

17 *Survival craft* is a craft capable of sustaining the lives of persons in distress from the time of abandoning the ship.

18 *Thermal protective aid* is a bag or suit made of waterproof material with low thermal conductivity.

Regulation 4

Evaluation, testing and approval of life-saving appliances and arrangements

- 1 Except as provided in paragraphs 5 and 6, life-saving appliances and arrangements required by this chapter shall be approved by the Administration.
- 2 Before giving approval to life-saving appliances and arrangements, the Administration shall ensure that such life-saving appliances and arrangements:
 - .1 are tested, to confirm that they comply with the requirements of this chapter, in accordance with the recommendations of the Organization;* or
 - .2 have successfully undergone, to the satisfaction of the Administration, tests which are substantially equivalent to those specified in those recommendations.
- 3 Before giving approval to novel life-saving appliances or arrangements, the Administration shall ensure that such appliances or arrangements:
 - .1 provide safety standards at least equivalent to the requirements of this chapter and have been evaluated and tested in accordance with the recommendations of the Organization;** or
 - .2 have successfully undergone, to the satisfaction of the Administration, evaluation and tests which are substantially equivalent to those recommendations.
- 4 Procedures adopted by the Administration for approval shall also include the conditions whereby approval would continue or would be withdrawn.
- 5 Before accepting life-saving appliances and arrangements that have not been previously approved by the Administration, the Administration shall be satisfied that life-saving appliances and arrangements comply with the requirements of this chapter.
- 6 Life-saving appliances required by this chapter for which detailed specifications are not included in part C shall be to the satisfaction of the Administration.

Regulation 5

Production tests

The Administration shall require life-saving appliances to be subjected to such production tests as are necessary to ensure that the life-saving appliances are manufactured to the same standard as the approved prototype.

*Reference is made to the "Recommendation on testing of life-saving appliances" to be submitted to the Assembly of the Organization at its thirteenth session for adoption.

**Reference is made to the "Code of practice for the evaluation, testing and acceptance of prototype novel life-saving appliances and arrangements" to be submitted to the Assembly of the Organization at its thirteenth session for adoption.

PART B—SHIP REQUIREMENTS

SECTION I—PASSENGER SHIPS AND CARGO SHIPS

Regulation 6

Communications

1 Paragraphs 2.3 and 2.4 apply to all ships. With respect to ships constructed before 1 July 1986, paragraphs 2.3 and 2.4 shall apply not later than 1 July 1991.

2 Radio life-saving appliances

2.1 Portable radio apparatus for survival craft

2.1.1 A portable radio apparatus for survival craft complying with the requirements of regulation IV/14 shall be provided. The portable radio apparatus shall be stowed in a protected and easily accessible position ready to be moved to any survival craft in an emergency, except that in the case of a ship with lifeboats stowed in widely separated positions fore and aft, the portable radio apparatus shall be stowed in the vicinity of the lifeboats which are furthest away from the ship's main transmitter.

2.1.2 The requirements of paragraph 2.1.1 need not be complied with if a radio installation complying with the requirements of regulation IV/13 is fitted in a lifeboat on each side of the ship or in the stern-launched lifeboat referred to in regulation 26.1.2.1.

2.1.3 On ships engaged on voyages of such duration that in the opinion of the Administration portable radio apparatus for survival craft is unnecessary, the Administration may allow such equipment to be dispensed with.

2.2 Radiotelegraph installation for lifeboats

On passenger ships engaged on international voyages which are not short international voyages:

- .1 where the total number of persons on board is more than 199 but less than 1,500, a radiotelegraph installation complying with the requirements of regulation IV/13 shall be fitted in at least one of the lifeboats required by regulation 20.1.1.1;
- .2 where the total number of persons on board is 1,500 or more, at least one lifeboat on each side shall be so fitted.

2.3 Survival craft emergency position-indicating radio beacons

One manually activated emergency position-indicating radio beacon complying with the requirements of regulation IV/14-1 shall be carried on each side of the ship. They shall be so stowed that they can be rapidly placed in any survival craft other than the liferaft or liferafts required by regulation 26.1.4.

2.4 Two-way radiotelephone apparatus

2.4.1 Two-way radiotelephone apparatus complying with the requirements of regulation IV/14-3 shall be provided for communication between survival craft, between survival craft and ship and between ship and rescue boat. An apparatus need not be provided for every survival craft; however, at least three apparatus shall be provided on each ship. This requirement may be complied with by other apparatus used on board provided such apparatus is not incompatible with the appropriate requirements of regulation IV/14-3.

2.4.2 For ships constructed before 1 July 1986 such apparatus need only comply with the frequency requirements of regulation IV/14-3.

3 Distress flares

Not less than 12 rocket parachute flares, complying with the requirements of regulation 35, shall be carried and be stowed on or near the navigating bridge.

4 *On-board communications and alarm systems*

4.1 An emergency means comprised of either fixed or portable equipment or both shall be provided for two-way communications between emergency control stations, muster and embarkation stations and strategic positions on board.

4.2 A general emergency alarm system complying with the requirements of regulation 50 shall be provided and shall be used for summoning passengers and crew to muster stations and to initiate the actions included in the muster list. The system shall be supplemented by either a public address system or other suitable means of communication.

Regulation 7

Personal life-saving appliances

1 *Lifebuoys*

1.1 Lifebuoys complying with the requirements of regulation 31.1 shall be:

- .1 so distributed as to be readily available on both sides of the ship and as far as practicable on all open decks extending to the ship's side; at least one shall be placed in the vicinity of the stern;
- .2 so stowed as to be capable of being rapidly cast loose, and not permanently secured in any way.

1.2 At least one lifebuoy on each side of the ship shall be fitted with a buoyant lifeline complying with the requirements of regulation 31.4 equal in length to not less than twice the height at which it is stowed above the waterline in the lightest seagoing condition, or 30 m, whichever is the greater.

1.3 Not less than one half of the total number of lifebuoys shall be provided with self-igniting lights complying with the requirements of regulation 31.2; not less than two of these shall also be provided with self-activating smoke signals complying with the requirements of regulation 31.3 and be capable of quick release from the navigating bridge; lifebuoys with lights and those with lights and smoke signals shall be equally distributed on both sides of the ship and shall not be the lifebuoys provided with lifelines in compliance with the requirements of paragraph 1.2.

1.4 Each lifebuoy shall be marked in block capitals of the Roman alphabet with the name and port of registry of the ship on which it is carried.

2 *Lifejackets*

2.1 A lifejacket complying with the requirements of regulation 32.1 or 32.2 shall be provided for every person on board the ship and, in addition:

- .1 a number of lifejackets suitable for children equal to at least 10% of the number of passengers on board shall be provided or such greater number as may be required to provide a lifejacket for each child;
- .2 a sufficient number of lifejackets shall be carried for persons on watch and for use at remotely located survival craft stations.

2.2 Lifejackets shall be so placed as to be readily accessible and their position shall be plainly indicated. Where, due to the particular arrangements of the ship, the lifejackets provided in compliance with the requirements of paragraph 2.1 may become inaccessible, alternative provisions shall be made to the satisfaction of the Administration which may include an increase in the number of lifejackets to be carried.

3 *Immersion suits*

3.1 An immersion suit, of an appropriate size, complying with the requirements of regulation 33 shall be provided for every person assigned to crew the rescue boat.

Regulation 8

Muster list and emergency instructions

- 1 This regulation applies to all ships.
- 2 Clear instructions to be followed in the event of an emergency shall be provided for every person on board.
- 3 Muster lists complying with the requirements of regulation 53 shall be exhibited in conspicuous places throughout the ship including the navigating bridge, engine-room and crew accommodation spaces.
- 4 Illustrations and instructions in appropriate languages shall be posted in passenger cabins and be conspicuously displayed at muster stations and other passenger spaces to inform passengers of:
 - .1 their muster station;
 - .2 the essential actions they must take in an emergency;
 - .3 the method of donning lifejackets.

Regulation 9

Operating instructions

- 1 This regulation applies to all ships.
- 2 Posters or signs shall be provided on or in the vicinity of survival craft and their launching controls and shall:
 - .1 illustrate the purpose of controls and the procedures for operating the appliance and give relevant instructions or warnings;
 - .2 be easily seen under emergency lighting conditions;
 - .3 use symbols in accordance with the recommendations of the Organization.

Regulation 10

Manning of survival craft and supervision

- 1 This regulation applies to all ships.
- 2 There shall be a sufficient number of trained persons on board for mustering and assisting untrained persons.
- 3 There shall be a sufficient number of crew members, who may be deck officers or certificated persons, on board for operating the survival craft and launching arrangements required for abandonment by the total number of persons on board.
- 4 A deck officer or certificated person shall be placed in charge of each survival craft to be used. However, the Administration, having due regard to the nature of the voyage, the number of persons on board and the characteristics of the ship, may permit persons practised in the handling and operation of liferafts to be placed in charge of liferafts in lieu of persons qualified as above. A second-in-command shall also be nominated in the case of lifeboats.
- 5 The person in charge of the survival craft shall have a list of the survival craft crew and shall see that the crew under his command are acquainted with their duties. In lifeboats the second-in-command shall also have a list of the lifeboat crew.
- 6 Every lifeboat required to carry a radiotelegraph installation complying with the requirements of regulation 6.2.2 shall have a person assigned who is capable of operating the equipment.

7 Every motorized survival craft shall have a person assigned who is capable of operating the engine and carrying out minor adjustments.

8 The master shall ensure the equitable distribution of persons referred to in paragraphs 2, 3 and 4 among the ship's survival craft.

Regulation 11

Survival craft muster and embarkation arrangements

1 Lifeboats and liferafts for which approved launching appliances are required shall be stowed as close to accommodation and service spaces as possible.

2 Muster stations shall be provided close to the embarkation stations. Each muster station shall have sufficient space to accommodate all persons assigned to muster at that station.

3 Muster and embarkation stations shall be readily accessible from accommodation and work areas.

4 Muster and embarkation stations shall be adequately illuminated by lighting supplied from the emergency source of electrical power required by regulation 11-1/42 or 11-1/43, as appropriate.

5 Alleyways, stairways and exits giving access to the muster and embarkation stations shall be lighted. Such lighting shall be capable of being supplied by the emergency source of electrical power required by regulation 11-1/42 or 11-1/43, as appropriate.

6 Davit-launched survival craft muster and embarkation stations shall be so arranged as to enable stretcher cases to be placed in survival craft.

7 An embarkation ladder complying with the requirements of regulation 48.7 extending, in a single length, from the deck to the waterline in the lightest seagoing condition under unfavourable conditions of trim and with the ship listed not less than 15° either way shall be provided at each launching station or at every two adjacent launching stations. However, the Administration may permit such ladders to be replaced by approved devices to afford access to the survival craft when waterborne, provided that there shall be at least one embarkation ladder on each side of the ship. Other means of embarkation may be permitted for the liferafts required by regulation 26.1.4.

8 Where necessary, means shall be provided for bringing the davit-launched survival craft against the ship's side and holding them alongside so that persons can be safely embarked.

Regulation 12

Launching stations

Launching stations shall be in such positions as to ensure safe launching having particular regard to clearance from the propeller and steeply overhanging portions of the hull and so that, as far as possible, survival craft, except survival craft especially designed for free-fall launching, can be launched down the straight side of the ship. If positioned forward, they shall be located abaft the collision bulkhead in a sheltered position and, in this respect, the Administration shall give special consideration to the strength of the launching appliance.

Regulation 13

Stowage of survival craft

1 Each survival craft shall be stowed:

- .1 so that neither the survival craft nor its stowage arrangements will interfere with the operation of any other survival craft or rescue boat at any other launching station;

- .2 as near the water surface as is safe and practicable and, in the case of a survival craft other than a liferaft intended for throw-overboard launching, in such a position that the survival craft in the embarkation position is not less than 2 m above the waterline with the ship in the fully loaded condition under unfavourable conditions of trim and listed up to 20° either way, or to the angle at which the ship's weatherdeck edge becomes submerged, whichever is less;
- .3 in a state of continuous readiness so that two crew members can carry out preparations for embarkation and launching in less than 5 min;
- .4 fully equipped as required by this chapter;
- .5 as far as practicable, in a secure and sheltered position and protected from damage by fire and explosion.

2 Lifeboats for lowering down the ship's side shall be stowed as far forward of the propeller as practicable. On cargo ships of 80 m in length and upwards but less than 120 m in length, each lifeboat shall be so stowed that the after end of the lifeboat is not less than the length of the lifeboat forward of the propeller. On cargo ships of 120 m in length and upwards and passenger ships of 80 m in length and upwards, each lifeboat shall be so stowed that the after end of the lifeboat is not less than 1.5 times the length of the lifeboat forward of the propeller. Where appropriate, the ship shall be so arranged that lifeboats, in their stowed positions, are protected from damage by heavy seas.

3 Lifeboats shall be stowed attached to launching appliances.

4 In addition to meeting the requirements of regulations 23 and 29, liferafts shall be so stowed as to permit manual release from their securing arrangements.

5 Davit-launched liferafts shall be stowed within reach of the lifting hooks, unless some means of transfer is provided which is not rendered inoperable within the limits of trim and list prescribed in paragraph 1.2 or by ship motion or power failure.

6 Liferafts intended for throw-overboard launching shall be so stowed as to be readily transferable for launching on either side of the ship unless liferafts, of the aggregate capacity required by regulation 26.1 to be capable of being launched on either side, are stowed on each side of the ship.

Regulation 14

Stowage of rescue boats

Rescue boats shall be stowed:

- .1 in a state of continuous readiness for launching in not more than 5 min;
- .2 in a position suitable for launching and recovery;
- .3 so that neither the rescue boat nor its stowage arrangements will interfere with the operation of any survival craft at any other launching station;
- .4 if it is also a lifeboat, in compliance with the requirements of regulation 13.

Regulation 15

Survival craft launching and recovery arrangements

1 Launching appliances complying with the requirements of regulation 48 shall be provided for all survival craft except:

- .1 survival craft which are boarded from a position on deck which is less than 4.5 m above the waterline in the lightest seagoing condition and which either:
 - .1.1 have a mass of not more than 185 kg; or
 - .1.2 are stowed for launching directly from the stowed position under unfavourable conditions of trim of up to 10° and with the ship listed not less than 20° either way;

.2 survival craft having a mass of not more than 185 kg and which are carried in excess of the survival craft for 200 % of the total number of persons on board the ship.

2 Each lifeboat shall be provided with an appliance which is capable of launching and recovering the lifeboat.

3 Launching and recovery arrangements shall be such that the appliance operator on the ship is able to observe the survival craft at all times during launching and for lifeboats during recovery.

4 Only one type of release mechanism shall be used for similar survival craft carried on board the ship.

5 Preparation and handling of survival craft at any one launching station shall not interfere with the prompt preparation and handling of any other survival craft or rescue boat at any other station.

6 Falls, where used, shall be long enough for the survival craft to reach the water with the ship in its lightest seagoing condition, under unfavourable conditions of trim and with the ship listed not less than 20° either way.

7 During preparation and launching, the survival craft, its launching appliance, and the area of water into which it is to be launched shall be adequately illuminated by lighting supplied from the emergency source of electrical power required by regulation 11-1/42 or II-1/43, as appropriate.

8 Means shall be available to prevent any discharge of water on to survival craft during abandonment.

9 If there is a danger of the survival craft being damaged by the ship's stabilizer wings, means shall be available, powered by an emergency source of energy, to bring the stabilizer wings inboard; indicators operated by an emergency source of energy shall be available on the navigating bridge to show the position of the stabilizer wings.

10 If lifeboats complying with the requirements of regulation 42 or 43 are carried, a davit span shall be provided, fitted with not less than two lifelines of sufficient length to reach the water with the ship in its lightest seagoing condition, under unfavourable conditions of trim and with the ship listed not less than 20° either way.

Regulation 16

Rescue boat embarkation, launching and recovery arrangements

1 The rescue boat embarkation and launching arrangements shall be such that the rescue boat can be boarded and launched in the shortest possible time.

2 If the rescue boat is one of the ship's survival craft, the embarkation arrangements and launching station shall comply with the requirements of regulations 11 and 12.

3 Launching arrangements shall comply with the requirements of regulation 15. However, all rescue boats shall be capable of being launched, where necessary utilizing painters, with the ship making headway at speeds up to 5 knots in calm water.

4 Rapid recovery of the rescue boat shall be possible when loaded with its full complement of persons and equipment. If the rescue boat is also a lifeboat, rapid recovery shall be possible when loaded with its lifeboat equipment and the approved rescue boat complement of at least six persons.

Regulation 17

Line-throwing appliances

A line-throwing appliance complying with the requirements of regulation 49 shall be provided.

Regulation 18

Abandon ship training and drills

1 This regulation applies to all ships.

2 *Manuals*

A training manual complying with the requirements of regulation 51 shall be provided in each crew messroom and recreation room or in each crew cabin.

3 *Practice musters and drills*

3.1 Each member of the crew shall participate in at least one abandon ship drill and one fire drill every month. The drills of the crew shall take place within 24 h of the ship leaving a port if more than 25% of the crew have not participated in abandon ship and fire drills on board that particular ship in the previous month. The Administration may accept other arrangements that are at least equivalent for those classes of ship for which this is impracticable.

3.2 On a ship engaged on an international voyage which is not a short international voyage, musters of the passengers shall take place within 24 h after their embarkation. Passengers shall be instructed in the use of the lifejackets and the action to take in an emergency. If only a small number of passengers embark at a port after the muster has been held it shall be sufficient, instead of holding another muster, to draw the attention of these passengers to the emergency instructions required by regulations 8.2 and 8.4.

3.3 On a ship engaged on a short international voyage, if a muster of the passengers is not held on departure, the attention of the passengers shall be drawn to the emergency instructions required by regulations 8.2 and 8.4.

3.4 Each abandon ship drill shall include.

- .1 summoning of passengers and crew to muster stations with the alarm required by regulation 6.4.2 and ensuring that they are made aware of the order to abandon ship specified in the muster list;
- .2 reporting to stations and preparing for the duties described in the muster list;
- .3 checking that passengers and crew are suitably dressed;
- .4 checking that lifejackets are correctly donned;
- .5 lowering of at least one lifeboat after any necessary preparation for launching;
- .6 starting and operating the lifeboat engine;
- .7 operation of davits used for launching liferafts.

3.5 Different lifeboats shall, as far as practicable, be lowered in compliance with the requirements of paragraph 3.4.5 at successive drills.

3.6 Drills shall, as far as practicable, be conducted as if there were an actual emergency.

3.7 Each lifeboat shall be launched with its assigned operating crew aboard and manoeuvred in the water at least once every 3 months during an abandon ship drill. The Administration may allow ships operating on short international voyages not to launch the lifeboats on one side if their berthing arrangements in port and their trading patterns do not permit launching of lifeboats on that side. However, all such lifeboats shall be lowered at least once every 3 months and launched at least annually.

3.8 As far as is reasonable and practicable, rescue boats other than lifeboats which are also rescue boats, shall be launched each month with their assigned crew aboard and manoeuvred in the water. In all cases this requirement shall be complied with at least once every 3 months.

3.9 If lifeboat and rescue boat launching drills are carried out with the ship making headway, such drills shall, because of the dangers involved, be practised in sheltered waters only and under the supervision of an officer experienced in such drills.

3.10 Emergency lighting for mustering and abandonment shall be tested at each abandon ship drill.

4 *On-board training and instructions*

4.1 On-board training in the use of the ship's life-saving appliances, including survival craft equipment, shall be given as soon as possible but not later than 2 weeks after a crew member joins the ship. However, if the crew member is on a regularly scheduled rotating assignment to the ship, such training shall be given not later than 2 weeks after the time of first joining the ship.

4.2 Instructions in the use of the ship's life-saving appliances and in survival at sea shall be given at the same interval as the drills. Individual instruction may cover different parts of the ship's life-saving system, but all the ship's life-saving equipment and appliances shall be covered within any period of 2 months. Each member of the crew shall be given instructions which shall include but not necessarily be limited to:

- .1 operation and use of the ship's inflatable liferafts;
- .2 problems of hypothermia, first-aid treatment for hypothermia and other appropriate first-aid procedures;
- .3 special instructions necessary for use of the ship's life-saving appliances in severe weather and severe sea conditions.

4.3 On-board training in the use of davit-launched liferafts shall take place at intervals of not more than 4 months on every ship fitted with such appliances. Whenever practicable this shall include the inflation and lowering of a liferaft. This liferaft may be a special liferaft intended for training purposes only, which is not part of the ship's life-saving equipment; such a special liferaft shall be conspicuously marked.

5 *Records*

The date when musters are held, details of abandon ship drills and fire drills, drills of other life-saving appliances and on-board training shall be recorded in such log-book as may be prescribed by the Administration. If a full muster, drill or training session is not held at the appointed time, an entry shall be made in the log-book stating the circumstances and the extent of the muster, drill or training session held.

Regulation 19

Operational readiness, maintenance and inspections

1 This regulation applies to all ships. The requirements of paragraphs 3 and 6.2 shall be complied with, as far as is practicable, on ships constructed before 1 July 1986.

2 *Operational readiness*

Before the ship leaves port and at all times during the voyage, all life-saving appliances shall be in working order and ready for immediate use.

3 *Maintenance*

3.1 Instructions for on-board maintenance of life-saving appliances complying with the requirements of regulation 52 shall be provided and maintenance shall be carried out accordingly.

3.2 The Administration may accept, in lieu of the instructions required by paragraph 3.1, a shipboard planned maintenance programme which includes the requirements of regulation 52.

4 *Maintenance of falls*

Falls used in launching shall be turned end for end at intervals of not more than 30 months and be renewed when necessary due to deterioration of the falls or at intervals of not more than 5 years, whichever is the earlier.

5 *Spares and repair equipment*

Spares and repair equipment shall be provided for life-saving appliances and their components which are subject to excessive wear or consumption and need to be replaced regularly.

6 *Weekly inspection*

The following tests and inspections shall be carried out weekly:

- .1 all survival craft, rescue boats and launching appliances shall be visually inspected to ensure that they are ready for use;
- .2 all engines in lifeboats and rescue boats shall be run ahead and astern for a total period of not less than 3 min provided the ambient temperature is above the minimum temperature required for starting the engine. In special cases the Administration may waive this requirement for ships constructed before 1 July 1986;
- .3 the general emergency alarm system shall be tested.

7 *Monthly inspections*

Inspection of the life-saving appliances, including lifeboat equipment, shall be carried out monthly using the checklist required by regulation 52.1 to ensure that they are complete and in good order. A report of the inspection shall be entered in the log-book.

8 *Servicing of inflatable liferafts, inflatable lifejackets and inflated rescue boats*

8.1 Every inflatable liferaft and inflatable lifejacket shall be serviced:

- .1 at intervals not exceeding 12 months. However, in cases where it appears proper and reasonable, the Administration may extend this period to 17 months;
- .2 at an approved servicing station which is competent to service them, maintains proper servicing facilities and uses only properly trained personnel. *

8.2 All repairs and maintenance of inflated rescue boats shall be carried out in accordance with the manufacturer's instructions. Emergency repairs may be carried out on board the ship; however, permanent repairs shall be effected at an approved servicing station.

9 *Periodic servicing of hydrostatic release units*

Hydrostatic release units shall be serviced:

- .1 at intervals not exceeding 12 months. However, in cases where it appears proper and reasonable, the Administration may extend this period to 17 months;
- .2 at a servicing station which is competent to service them, maintains proper servicing facilities and uses only properly trained personnel.

*Reference is made to the "Recommendation on the conditions for the approval of servicing stations for inflatable liferafts" adopted by the Organization by resolution A.333(IX).

SECTION II—PASSENGER SHIPS

(ADDITIONAL REQUIREMENTS)

Regulation 20

Survival craft and rescue boats

1 *Survival craft*

1.1 Passenger ships engaged on international voyages which are not short international voyages shall carry:

- .1 lifeboats complying with the requirements of regulation 42, 43, or 44 on each side of such aggregate capacity as will accommodate not less than 50 per cent of the total number of persons on board. The Administration may permit the substitution of lifeboats by liferafts of equivalent total capacity provided that there shall never be less than sufficient lifeboats on each side of the ship to accommodate 37.5 per cent of the total number of persons on board. The liferafts shall comply with the requirements of regulation 39 or 40 and shall be served by launching appliances equally distributed on each side of the ship; and
- .2 in addition, liferafts complying with the requirements of regulation 39 or 40 of such aggregate capacity as will accommodate at least 25% of the total number of persons on board. These liferafts shall be served by at least one launching appliance on each side which may be those provided in compliance with the requirements of paragraph 1.1.1 or equivalent approved appliances capable of being used on both sides. However, stowage of these liferafts need not comply with the requirements of regulation 13.5.

1.2 Passenger ships engaged on short international voyages and complying with the special standards of subdivision prescribed by regulation 11-1/6.5 shall carry:

- .1 lifeboats complying with the requirements of regulation 42, 43 or 44 equally distributed, as far as practicable, on each side of the ship and of such aggregate capacity as will accommodate at least 30% of the total number of persons on board and liferafts complying with requirements of regulation 39 or 40 of such aggregate capacity that, together with the lifeboat capacity, the survival craft will accommodate the total number of persons on board. The liferafts shall be served by launching appliances equally distributed on each side of the ship; and
- .2 in addition, liferafts complying with the requirements of regulation 39 or 40 of such aggregate capacity as will accommodate at least 25% of the total number of persons on board. These liferafts shall be served by at least one launching appliance on each side which may be those provided in compliance with the requirements of paragraph 1.2.1 or equivalent approved appliances capable of being used on both sides. However, stowage of these liferafts need not comply with the requirements of regulation 13.5.

1.3 Passenger ships engaged on short international voyages and not complying with the special standard of subdivision prescribed by regulation 11-1/6.5, shall carry survival craft complying with the requirements of paragraph 1.1.

1.4 All survival craft required to provide for abandonment by the total number of persons on board shall be capable of being launched with their full complement of persons and equipment within a period of 30 minutes from the time the abandon ship signal is given.

1.5 In lieu of meeting the requirements of paragraph 1.1, 1.2 or 1.3, passenger ships of less than 500 tons gross tonnage where the total number of persons on board is less than 200, may comply with the following:

- .1 They shall carry on each side of the ship, liferafts complying with the requirements of regulation 39 or 40 and of such aggregate capacity as will accommodate the total number of persons on board.

- .2 Unless the liferafts required by paragraph 1.5.1 can be readily transferred for launching on either side of the ship, additional liferafts shall be provided so that the total capacity available on each side will accommodate 150% of the total number of persons on board.
- .3 If the rescue boat required by paragraph 2.2 is also a lifeboat complying with the requirements of regulation 42, 43 or 44, it may be included in the aggregate capacity required by paragraph 1.5.1, provided that the total capacity available on either side of the ship is at least 150% of the total number of persons on board.
- .4 In the event of any one survival craft being lost or rendered unserviceable, there shall be sufficient survival craft available for use on each side to accommodate the total number of persons on board.

2 *Rescue boats*

2.1 Passenger ships of 500 gross tonnage and over shall carry at least one rescue boat complying with the requirements of regulation 47 on each side of the ship.

2.2 Passenger ships of less than 500 tons gross tonnage shall carry at least one rescue boat complying with the requirements of regulation 47.

2.3 A lifeboat may be accepted as a rescue boat provided it also complies with the requirements for a rescue boat.

3 *Marshalling of liferafts*

3.1 The number of lifeboats and rescue boats that are carried on passenger ships shall be sufficient to ensure that in providing for abandonment by the total number of persons on board not more than six liferafts need be marshalled by each lifeboat or rescue boat.

3.2 The number of lifeboats and rescue boats that are carried on passenger ships engaged on short international voyages and complying with the special standards of subdivision prescribed by regulation 11-1/6.5 shall be sufficient to ensure that in providing for abandonment by the total number of persons on board not more than nine liferafts need be marshalled by each lifeboat or rescue boat.

Regulation 21

Personal life-saving appliances

1 *Lifebuoys*

1.1 A passenger ship shall carry not less than the number of lifebuoys complying with the requirements of regulations 7.1 and 31 prescribed in the following table:

Length of ship in metres	Minimum number of lifebuoys
Under 60	8
60 and under 120	12
120 and under 180	18
180 and under 240	24
240 and over	30

1.2 Notwithstanding regulation 7.1.3, passenger ships of under 60 m in length shall carry not less than six lifebuoys provided with self-igniting lights.

2 *Lifejackets*

In addition to the lifejackets required by regulation 7.2, every passenger ship shall carry lifejackets for not less than 5% of the total number of persons on board. These lifejackets shall be stowed in conspicuous places on deck or at muster stations.

3 *Lifejacket lights*

3.1 This paragraph applies to all passenger ships. With respect to passenger ships constructed before 1 July 1986, the requirements of this paragraph shall apply not later than 1 July 1991.

3.2 On passenger ships engaged on international voyages which are not short international voyages each lifejacket shall be fitted with a light complying with the requirements of regulation 32.3.

4 *Immersion suits and thermal protective aids*

4.1 This paragraph applies to all passenger ships. With respect to passenger ships constructed before 1 July 1986, the requirements of this paragraph shall apply not later than 1 July 1991.

4.2 Passenger ships shall carry for each lifeboat on the ship at least three immersion suits complying with the requirements of regulation 33 and, in addition, a thermal protective aid complying with the requirements of regulation 34 for every person to be accommodated in the lifeboat and not provided with an immersion suit. These immersion suits and thermal protective aids need not be carried:

- .1 for persons to be accommodated in totally or partially enclosed lifeboats; or
- .2 if the ship is constantly engaged on voyages in warm climates where, in the opinion of the Administration, thermal protective aids are unnecessary.

4.3 The provisions of paragraph 4.2.1 also apply to totally or partially enclosed lifeboats not complying with the requirements of regulation 42, 43 or 44, provided they are carried on ships constructed before 1 July 1986.

Regulation 22

Survival craft and rescue boat embarkation arrangements

1 **On** passenger ships, survival craft embarkation arrangements shall be designed for:

- .1 all lifeboats to be boarded and launched either directly from the stowed position or from an embarkation deck but not both;
- .2 davit-launched liferafts to be boarded and launched from a position immediately adjacent to the stowed position or from a position to which, in compliance with the requirements of regulation 13.5, the liferaft is transferred prior to launching.

2 Rescue boat arrangements shall be such that the rescue boat can be boarded and launched directly from the stowed position with the number of persons assigned to crew the rescue boat on board. Notwithstanding the requirements of paragraph 1.1, if the rescue boat is also a lifeboat and other lifeboats are boarded and launched from an embarkation deck, the arrangements shall be such that the rescue boat can also be boarded and launched from the embarkation deck.

Regulation 23

Stowage of liferafts

On passenger ships, every liferaft shall be stowed with its painter permanently attached to the ship and with a float-free arrangement complying with the requirements of regulation 38.6 so that, as far as practicable, the liferafts floats free and, if inflatable, inflates automatically when the ship sinks.

Regulation 24

Muster stations

Every passenger ship shall, in addition to complying with the requirements of regulation 11, have passenger muster stations which shall:

- .1 be in the vicinity of, and permit ready access for the passengers to, the embarkation stations unless in the same location;
- .2 have ample room for marshalling and instruction of the passengers.

Regulation 25

Drills

- 1 This regulation applies to all passenger ships.
- 2 On passenger ships, an abandon ship drill and fire drill shall take place weekly.

SECTION III—CARGO SHIPS

(ADDITIONAL REQUIREMENTS)

Regulation 26

Survival craft and rescue boats

1 *Survival craft*

1.1 Cargo ships shall carry:

- .1 one or more lifeboats complying with the requirements of regulation 44 of such aggregate capacity on each side of the ship as will accommodate the total number of persons on board. The Administration may, however, permit cargo ships (except oil tankers, chemical tankers and gas carriers) operating under favourable climatic conditions and in suitable areas, to carry lifeboats complying with the requirements of regulation 43, provided the limits of the trade area are specified in the Cargo Ship Safety Equipment Certificate; and
- .2 in addition, a liferaft or liferafts, complying with the requirements of regulation 39 or 40, capable of being launched on either side of the ship and of such aggregate capacity as will accommodate the total number of persons on board. If the liferaft or liferafts cannot be readily transferred for launching on either side of the ship, the total capacity available on each side shall be sufficient to accommodate the total number of persons on board.

1.2 In lieu of meeting the requirements of paragraph 1.1, cargo ships may carry:

- .1 one or more lifeboats, complying with the requirements of regulation 44, capable of being free fall launched over the stern of the ship of such aggregate capacity as will accommodate the total number of persons on board; and
- .2 in addition, one or more liferafts complying with the requirements of regulation 39 or 40, on each side of the ship, of such aggregate capacity as will accommodate the total number of persons on board. The liferafts on at least one side of the ship shall be served by launching appliances.

1.3 In lieu of meeting the requirements of paragraph 1.1 or 1.2, cargo ships of less than 85 m in length other than oil tankers and gas carriers, may comply with the following:

- .1 They shall carry on each side of the ship, one or more liferafts complying with the requirements of regulation 39 or 40 and of such aggregate capacity as will accommodate the total number of persons on board.
- .2 Unless the liferafts required by paragraph 1.3.1 can be readily transferred for launching on either side of the ship, additional liferafts shall be provided so that the total capacity available on each side will accommodate 150% of the total number of persons on board.

- .3 If the rescue boat required by paragraph 2 is also a lifeboat complying with the requirements of regulation 43 or 44, it may be included in the aggregate capacity required by paragraph 1.3.1, provided that the total capacity available on either side of the ship is at least 150% of the total number of persons on board.
- .4 In the event of any one survival craft being lost or rendered unserviceable, there shall be sufficient survival craft available for use on each side to accommodate the total number of persons on board.

1.4 Cargo ships where the survival craft are stowed in a position which is more than 100 m from the stem or stern shall carry, in addition to the liferafts required by paragraphs 1.1.2 and 1.2.2, a liferaft stowed as far forward or aft, or one as far forward and another as far aft, as is reasonable and practicable. Notwithstanding the requirements of regulation 29, such liferaft or liferafts may be securely fastened so as to permit manual release and need not be of the type which can be launched from an approved launching device.

1.5 With the exception of the survival craft referred to in regulation 15.1.1, all survival craft required to provide for abandonment by the total number of persons on board shall be capable of being launched with their full complement of persons and equipment within a period of 10 min from the time the abandon ship signal is given.

1.6 Chemical tankers and gas carriers carrying cargoes emitting toxic vapours or gases* shall carry, in lieu of lifeboats complying with the requirements of regulation 43 or 44, lifeboats complying with the requirements of regulation 45.

1.7 Oil tankers, chemical tankers and gas carriers carrying cargoes having a flashpoint not exceeding 60° C (closed cup test) shall carry, in lieu of lifeboats complying with the requirements of regulation 43 or 44, lifeboats complying with the requirements of regulation 46.

2 Rescue boats

Cargo ships shall carry at least one rescue boat complying with the requirements of regulation 47. A lifeboat may be accepted as a rescue boat, provided that it also complies with the requirements for a rescue boat.

3 In addition to their lifeboats, cargo ships constructed before 1 July 1986 shall carry not later than 1 July 1991:

- .1 one or more liferafts of such aggregate capacity as will accommodate the total number of persons on board. The liferaft or liferafts shall be equipped with a lashing or an equivalent means of securing the liferaft which will automatically release it from a sinking ship;
- .2 where the survival craft are stowed in a position which is more than 100 m from the stem or stern, in addition to the liferafts required by paragraph 3.1, a liferaft stowed as far forward or aft, or one as far forward and another as far aft, as is reasonable and practicable. Notwithstanding the requirements of paragraph 3.1, such liferaft or liferafts may be securely fastened so as to permit manual release.

*Reference is made to Products for which emergency escape respiratory protection is required in chapter 17 of the International Code for the Construction and Equipment of Ships Carrying Dangerous Chemicals in Bulk (IBC Code) adopted by the Maritime Safety Committee by resolution MSC.4(48)¹ and in chapter 19 of the International Code for the Construction and Equipment of Ships Carrying Liquefied Gases in Bulk (IGC Code) adopted by the Maritime Safety Committee by resolution MSC.5(48)².

¹Treaty Series No. 13. Cm 3926.

²Treaty Series No. 15. Cm 3928.

Regulation 27

Personal life-saving appliances

1 *Lifebuoys*

1.1 Cargo ships shall carry not less than the number of lifebuoys complying with the requirements of regulations 7.1 and 31 prescribed in the following table:

Length of ship in metres	Minimum number of lifebuoys
Under 100	8
100 and under 150	10
150 and under 200	12
200 and over	14

1.2 Self-igniting lights for lifebuoys on tankers required by regulation 7.1.3 shall be of an electric battery type.

2 *Lifejacket lights*

2.1 This paragraph applies to all cargo ships. With respect to cargo ships constructed before 1 July 1986, this paragraph shall apply not later than 1 July 1991.

2.2 On cargo ships, each lifejacket shall be fitted with a light complying with the requirements of regulation 32.3.

3 *Immersion suits and thermal protective aids*

3.1 This paragraph applies to all cargo ships. With respect to cargo ships constructed before 1 July 1986, this paragraph shall apply not later than 1 July 1991.

3.2 Cargo ships shall carry for each lifeboat on the ship at least three immersion suits complying with the requirements of regulation 33 or, if the Administration considers it necessary and practicable, one immersion suit complying with the requirements of regulation 33 for every person on board the ship; however, the ship shall carry in addition to the thermal protective aids required by regulations 38.5.1.24, 41.8.31 and 47.2.2.13, thermal protective aids complying with the requirements of regulation 34 for persons on board not provided with immersion suits. These immersion suits and thermal protective aids need not be required if the ship:

- .1 has totally enclosed lifeboats on each side of the ship of such aggregate capacity as will accommodate the total number of persons on board; or
- .2 has totally enclosed lifeboats capable of being launched by free-fall over the stern of the ship of such aggregate capacity as will accommodate the total number of persons on board and which are boarded and launched directly from the stowed position, together with liferafts on each side of the ship of such aggregate capacity as will accommodate the total number of persons on board; or
- .3 is constantly engaged on voyages in warm climates where, in the opinion of the Administration, immersion suits are unnecessary.

3.3 Cargo ships complying with the requirements of regulation 26.1.3 shall carry immersion suits complying with the requirements of regulation 33 for every person on board unless the ship:

- .1 has davit-launched liferafts; or
- .2 has liferafts served by equivalent approved appliances capable of being used on both sides of the ship and which do not require entry into the water to board the liferaft; or
- .3 is constantly engaged on voyages in warm climates where, in the opinion of the Administration, immersion suits are unnecessary.

3.4 The immersion suits required by this regulation may be used to comply with the requirements of regulation 7.3

3.5 The totally enclosed lifeboats referred to in paragraphs 3.2.1 and 3.2.2 carried on cargo ships constructed before 1 July 1986 need not comply with the requirements of regulation 44.

Regulation 28

Survival craft embarkation and launching arrangements

1 Cargo ship survival craft embarkation arrangements shall be so designed that lifeboats can be boarded and launched directly from the stowed position and davit-launched liferafts can be boarded and launched from a position immediately adjacent to the stowed position or from a position to which the liferaft is transferred prior to launching in compliance with the requirements of regulation 13.5.

2 On cargo ships of 20,000 tons gross tonnage and upwards, lifeboats shall be capable of being launched, where necessary utilizing painters, with the ship making headway at speeds of up to 5 knots in calm water.

Regulation 29

Stowage of liferafts

On cargo ships, every liferaft, other than those required by regulations 26.1.4, shall be stowed with its painter permanently attached to the ship and with a float-free arrangement complying with the requirements of regulation 38.6 so that the liferaft floats free and, if inflatable, inflates automatically when the ship sinks.

PART C—LIFE-SAVING APPLIANCE REQUIREMENTS

SECTION I—GENERAL

Regulation 30

General requirements for life-saving appliances

1 Paragraph 2.7 applies to all ships. With respect to ships constructed before 1 July 1986, paragraph 2.7 shall apply not later than 1 July 1991.

2 Unless expressly provided otherwise or unless, in the opinion of the Administration having regard to the particular voyages on which the ship is constantly engaged, other requirements are appropriate, all life-saving appliances prescribed in this part shall:

- .1 be constructed with proper workmanship and materials;
- .2 not be damaged in stowage throughout the air temperature range — 30°C to + 65°C;
- .3 if they are likely to be immersed in seawater during their use, operate throughout the seawater temperature range — 1°C to + 30°C;
- .4 where applicable, be rot-proof, corrosion-resistant, and not be unduly affected by seawater, oil or fungal attack;
- .5 where exposed to sunlight, be resistant to deterioration;
- .6 be of a highly visible colour on all parts where this will assist detection;
- .7 be fitted with retro-reflective material where it will assist in detection and in accordance with the recommendations of the Organization*;
- .8 if they are to be used in a seaway, be capable of satisfactory operation in that environment.

*Reference is made to the "Recommendation on retro-reflective tapes on life-saving appliances" adopted by the Organization in resolution A.274(VIII).

3 The Administration shall determine the period of acceptability of life-saving appliances which are subject to deterioration with age. Such life-saving appliances shall be marked with a means of determining their age or the date by which they must be replaced.

SECTION II—PERSONAL LIFE-SAVING APPLIANCES

Regulation 31

Lifebuoys

1 *Lifebuoy specification*

Every lifebuoy shall:

- .1 have an outer diameter of not more than 800 mm and an inner diameter of not less than 400 mm;
- .2 be constructed of inherently buoyant material; it shall not depend upon rushes, cork shavings or granulated cork, any other loose granulated material or any air compartment which depends on inflation for buoyancy;
- .3 be capable of supporting not less than 14.5 kg of iron in fresh water for a period of 24 hr;
- .4 have a mass of not less than 2.5 kg;
- .5 not sustain burning or continue melting after being totally enveloped in a fire for a period of 2 s;
- .6 be constructed to withstand a drop into the water from the height at which it is stowed above the waterline in the lightest seagoing condition or 30 m, whichever is the greater, without impairing either its operating capability or that of its attached components;
- .7 if it is intended to operate the quick-release arrangement provided for the self-activated smoke signals and self-igniting lights, have a mass sufficient to operate the quick-release arrangement or 4 kg, whichever is the greater;
- .8 be fitted with a grabline not less than 9.5 mm in diameter and not less than 4 times the outside diameter of the body of the buoy in length. The grabline shall be secured at four equidistant points around the circumference of the buoy to form four equal loops.

2 *Lifebuoy self-igniting lights*

Self-igniting lights required by regulation 7.1.3 shall be:

- .1 be such that they cannot be extinguished by water;
- .2 be capable of either burning continuously with a luminous intensity of not less than 2 cd in all directions of the upper hemisphere or flashing (discharge flashing) at a rate of not less than 50 flashes per minute with at least the corresponding effective luminous intensity;
- .3 be provided with a source of energy capable of meeting the requirement of paragraph 2.2 for a period of at least 2 hr;
- .4 be capable of withstanding the drop test required by paragraph 1.6.

3 *Lifebuoy self-activating smoke signals*

Self-activating smoke signals required by regulation 7.1.3 shall:

- .1 emit smoke of a highly visible colour at a uniform rate for a period of at least 15 min when floating in calm water;
- .2 not ignite explosively or emit any flame during the entire smoke emission time of the signal;
- .3 not be swamped in a seaway;
- .4 continue to emit smoke when fully submerged in water for a period of at least 10 s;
- .5 be capable of withstanding the drop test required by paragraph 1.6.

4 *Buoyant lifelines*

Buoyant lifelines required by regulation 7.1.2 shall:

- .1 be non-kinking;
- .2 have a diameter of not less than 8 mm;
- .3 have a breaking strength of not less than 5 kN.

Regulation 32

Lifejackets

1 *General requirements for lifejackets*

1.1 A lifejacket shall not sustain burning or continue melting after being totally enveloped in a fire for a period of 2 s.

1.2 A lifejacket shall be so constructed that:

- .1 after demonstration, a person can correctly don it within a period of 1 min without assistance;
- .2 it is capable of being worn inside-out or is clearly capable of being worn in only one way and, as far as possible, cannot be donned incorrectly;
- .3 it is comfortable to wear;
- .4 it allows the wearer to jump from a height of at least 4.5 m into the water without injury and without dislodging or damaging the lifejacket.

1.3 A lifejacket shall have sufficient buoyance and stability in calm fresh water to:

- .1 lift the mouth of an exhausted or unconscious person not less than 120 mm clear of the water with the body inclined backwards at an angle of not less than 20° and not more than 50° from the vertical position;
- .2 turn the body of an unconscious person in the water from any position to one where the mouth is clear of the water in not more than 5 s.

1.4 A lifejacket shall have buoyancy which is not reduced by more than 5% after 24 h submersion in fresh water.

1.5 A lifejacket shall allow the person wearing it to swim a short distance and to board a survival craft.

1.6 Each lifejacket shall be fitted with a whistle firmly secured by a cord.

2 *Inflatable lifejackets*

A lifejacket which depends on inflation for buoyancy shall have not less than two separate compartments and comply with the requirements of paragraph 1 and shall:

- .1 inflate automatically on immersion, be provided with a device to permit inflation by a single manual motion and be capable of being inflated by mouth;
- .2 in the event of loss of buoyancy in any one compartment be capable of complying with the requirements of paragraphs 1.2, 1.3 and 1.5;
- .3 comply with the requirements of paragraph 1.4 after inflation by means of the automatic mechanism.

3 *Lifejacket lights*

3.1 Each lifejacket light shall:

- .1 have a luminous intensity of not less than 0.75 cd;
- .2 have a source of energy capable of providing a luminous intensity of 0.75 cd for a period of at least 8 h;
- .3 be visible over as great a segment of the upper hemisphere as is practicable when attached to a lifejacket.

- 3.2 If the light referred to in paragraph 3.1 is a flashing light it shall, in addition:
- .1 be provided with a manually operated switch;
 - .2 not be fitted with a lens or curved reflector to concentrate the beam;
 - .3 flash at a rate of not less than 50 flashes per minute with an effective luminous intensity of at least 0.75 cd.

Regulation 33

Immersion suits

1 *General requirements for immersion suits*

- 1.1 The immersion suit shall be constructed with waterproof materials such that:
- .1 it can be unpacked and donned without assistance within 2 min, taking into account any associated clothing*, and a lifejacket if the immersion suit is to be worn in conjunction with a lifejacket;
 - .2 it will not sustain burning or continue melting after being totally enveloped in a fire for a period of 2 s;
 - .3 it will cover the whole body with the exception of the face. Hands shall also be covered unless permanently attached gloves are provided;
 - .4 it is provided with arrangements to minimize or reduce free air in the legs of the suit;
 - .5 following a jump from a height of not less than 4.5 m into the water there is no undue ingress of water into the suit.

1.2 An immersion suit which also complies with the requirements of regulation 32 may be classified as a lifejacket.

1.3 An immersion suit shall permit the person wearing it, and also wearing a life-jacket if the immersion suit is to be worn in conjunction with a lifejacket, to:

- .1 climb up and down a vertical ladder at least 5 m in length;
- .2 perform normal duties during abandonment;
- .3 jump from a height of not less than 4.5 m into the water without damaging or dislodging the immersion suit, or being injured; and
- .4 swim a short distance through the water and board a survival craft.

1.4 An immersion suit which has buoyancy and is designed to be worn without a lifejacket shall be fitted with a light complying with the requirements of regulation 32.3 and the whistle prescribed by regulation 32.1.6.

1.5 If the immersion suit is to be worn in conjunction with a lifejacket, the lifejacket shall be worn over the immersion suit. A person wearing such an immersion suit shall be able to don a lifejacket without assistance.

2 *Thermal performance requirements for immersion suits*

- 2.1 An immersion suit made of material which has no inherent insulation shall be:
- .1 marked with instructions that it must be worn in conjunction with warm clothing;
 - .2 so constructed that, when worn in conjunction with warm clothing, and with a lifejacket if the immersion suit is to be worn with a lifejacket, the immersion suit continues to provide sufficient thermal protection, following one jump by the wearer into the water from a height of 4.5 m, to ensure that when it is worn for a period of 1 h in calm circulating water at a temperature of 5°C, the wearer's body core temperature does not fall more than 2°C.

*Reference is made to paragraph 3.1.3.1 of the "Recommendation on testing of life-saving appliances" to be submitted to the Assembly of the Organization at its thirteenth session for adoption.

2.2 An immersion suit made of material with inherent insulation, when worn either on its own or with a lifejacket, if the immersion suit is to be worn in conjunction with a lifejacket, shall provide the wearer with sufficient thermal insulation, following one jump into the water from a height of 4.5 m, to ensure that the wearer's body core temperature does not fall more than 2°C after a period of 6 h immersion in calm circulating water at a temperature of between 0°C and 2°C.

2.3 The immersion suit shall permit the person wearing it with hands covered to pick up a pencil and write after being immersed in water at 5°C for a period of 1 h.

3 *Buoyancy requirements*

A person in fresh water wearing either an immersion suit complying with the requirements of regulation 32, or an immersion suit with a lifejacket, shall be able to turn from a face-down to a face-up position in not more than 5 s.

Regulation 34

Thermal protective aids

1 A thermal protective aid shall be made of waterproof material having a thermal conductivity of not more than 0.25 W/(m•K) and shall be so constructed that, when used to enclose a person, it shall reduce both the convective and evaporative heat loss from the wearer's body.

2 The thermal protective aid shall:

- .1 cover the whole body of a person wearing a lifejacket with the exception of the face. Hands shall also be covered unless permanently attached gloves are provided;
- .2 be capable of being unpacked and easily donned without assistance in a survival craft or rescue boat;
- .3 permit the wearer to remove it in the water in not more than 2 min, if it impairs ability to swim.

3 The thermal protective aid shall function properly throughout an air temperature range -30°C to + 20°C.

SECTION III—VISUAL SIGNALS

Regulation 35

Rocket parachute flares

1 The rocket parachute flare shall:

- .1 be contained in a water-resistant casing;
- .2 have brief instructions or diagrams clearly illustrating the use of the rocket parachute flare printed on its casing;
- .3 have integral means of ignition;
- .4 be so designed as not to cause discomfort to the person holding the casing when used in accordance with the manufacturer's operating instructions.

2 The rocket shall, when fired vertically, reach an altitude of not less than 300 m. At or near the top of its trajectory, the rocket shall eject a parachute flare, which shall:

- .1 burn with a bright red colour;
- .2 burn uniformly with an average luminous intensity of not less than 30,000 cd;
- .3 have a burning period of not less than 40 s;
- .4 have a rate of descent of not more than 5 m/s;
- .5 not damage its parachute or attachments while burning.

Regulation 36

Hand flares

- 1 The hand flare shall:
 - .1 be contained in a water-resistant casing;
 - .2 have brief instructions or diagrams clearly illustrating the use of the hand flare printed on its casing;
 - .3 have a self-contained means of ignition;
 - .4 be so designed as not to cause discomfort to the person holding the casing and not endanger the survival craft by burning or glowing residues when used in accordance with the manufacturer's operating instructions.
- 2 The hand flare shall:
 - .1 burn with a bright red colour;
 - .2 burn uniformly with an average luminous intensity of not less than 15,000 cd;
 - .3 have a burning period of not less than 1 min;
 - .4 continue to burn after having been immersed for a period of 10 s under 100 mm of water.

Regulation 37

Buoyant smoke signals

- 1 The buoyant smoke signal shall:
 - .1 be contained in a water-resistant casing;
 - .2 not ignite explosively when used in accordance with the manufacturer's operating instructions;
 - .3 have brief instructions or diagrams clearly illustrating the use of the buoyant smoke signal printed on its casing.
- 2 The buoyant smoke signal shall:
 - .1 emit smoke of a highly visible colour at a uniform rate for a period of not less than 3 min when floating in calm water;
 - .2 not emit any flame during the entire smoke emission time;
 - .3 not be swamped in a seaway;
 - .4 continue to emit smoke when submerged in water for a period of 10 s under 100 mm of water.

SECTION IV—SURVIVAL CRAFT

Regulation 38

General requirements for liferafts

1 *Construction of liferafts*

1.1 Every liferaft shall be so constructed as to be capable of withstanding exposure for 30 days afloat in all sea conditions.

1.2 The liferaft shall be so constructed that when it is dropped into the water from a height of 18 metres, the liferaft and its equipment will operate satisfactorily. If the liferaft is to be stowed at a height of more than 18 m above the waterline in the lightest seagoing condition, it shall be of a type which has been satisfactorily drop-tested from at least that height.

1.3 The floating liferaft shall be capable of withstanding repeated jumps on to it from a height of at least 4.5 m above its floor both with and without the canopy erected.

1.4 The liferaft and its fittings shall be so constructed as to enable it to be towed at a speed of 3 knots in calm water when loaded with its full complement of persons and equipment and with one of its sea-anchors streamed.

1.5 The liferaft shall have a canopy to protect the occupants from exposure which is automatically set in place when the liferaft is launched and waterborne. The canopy shall comply with the following:

- .1 it shall provide insulation against heat and cold by means of either two layers of material separated by an air gap or other equally efficient means. Means shall be provided to prevent accumulation of water in the air gap;
- .2 its interior shall be of a colour that does not cause discomfort to the occupants;
- .3 each entrance shall be clearly indicated and be provided with efficient adjustable closing arrangements which can be easily and quickly opened from inside and outside the liferaft so as to permit ventilation but exclude seawater, wind and cold. Liferafts accommodating more than eight persons shall have at least two diametrically opposite entrances;
- .4 it shall admit sufficient air for the occupants at all times, even with the entrances closed;
- .5 it shall be provided with at least one viewing port;
- .6 it shall be provided with means for collecting rain water;
- .7 it shall have sufficient headroom for sitting occupants under all parts of the canopy.

2 Minimum carrying capacity and mass of liferafts

2.1 No liferaft shall be approved which has a carrying capacity of less than six persons calculated in accordance with the requirements of regulation 39.3 or 40.3, as appropriate.

2.2 Unless the liferaft is to be launched by an approved launching appliance complying with the requirements of regulation 48 and is not required to be portable, the total mass of the liferaft, its container and its equipment shall not be more than 185 kg.

3 Liferaft fittings

3.1 Lifelines shall be securely becketed around the inside and outside of the liferaft.

3.2 The liferaft shall be provided with arrangements for adequately siting and securing in the operating position the antenna provided with the portable radio apparatus required by regulation 6.2.1.

3.3 The liferaft shall be fitted with an efficient painter of length equal to not less than twice the distance from the stowed position to the waterline in the lightest seagoing condition or 15 m whichever is the greater.

4 Davit-launched Liferafts

4.1 In addition to the above requirements, a liferaft for use with an approved launching appliance shall:

- .1 when the liferaft is loaded with its full complement of persons and equipment, be capable of withstanding a lateral impact against the ship's side at an impact velocity of not less than 3.5 m/s and also a drop into the water from a height of not less than 3 m without damage that will affect its function;
- .2 be provided with means for bringing the liferaft alongside the embarkation deck and holding it securely during embarkation.

4.2 Every passenger ship davit-launched liferaft shall be so arranged that it can be rapidly boarded by its full complement of persons.

4.3 Every cargo ship davit-launched liferaft shall be so arranged that it can be boarded by its full complement of persons in not more than 3 min from the time the instruction to board is given.

5 *Equipment*

5.1 The normal equipment of every liferaft shall consist of:

- .1 one buoyant rescue quoit, attached to not less than 30 m of buoyant line;
- .2 one knife of the non-folding type having a buoyant handle and lanyard attached and stowed in a pocket on the exterior of the canopy near the point at which the painter is attached to the liferaft. In addition, a liferaft which is permitted to accommodate 13 persons or more shall be provided with a second knife which need not be of the non-folding type;
- .3 for a liferaft which is permitted to accommodate not more than 12 persons, one buoyant bailer. For a liferaft which is permitted to accommodate 13 persons or more, two buoyant bailers;
- .4 two sponges;
- .5 two sea-anchors each with a shock-resistant hawser and tripping line, one being spare and the other permanently attached to the liferaft in such a way that when the liferaft inflates or is waterborne it will cause the liferaft to lie oriented to the wind in the most stable manner. The strength of each sea-anchor and its hawser and tripping line shall be adequate for all sea conditions. The sea-anchors shall be fitted with a swivel at each end of the line and shall be of a type which is unlikely to turn inside-out between its shroud lines;
- .6 two buoyant paddles;
- .7 three tin openers. Safety knives containing special tin-opener blades are satisfactory for this requirement;
- .8 one first-aid outfit in a waterproof case capable of being closed tightly after use;
- .9 one whistle or equivalent sound signal;
- .10 four rocket parachute flares complying with the requirements of regulation 35;
- .11 six hand flares complying with the requirements of regulation 36;
- .12 two buoyant smoke signals complying with the requirements of regulation 37;
- .13 one waterproof electric torch suitable for Morse signalling together with one spare set of batteries and one spare bulb in a waterproof container;
- .14 an efficient radar reflector;
- .15 one daylight signalling mirror with instructions on its use for signalling to ships and aircraft;
- .16 one copy of the life-saving signals referred to in regulation V/16 on a waterproof card or in a waterproof container;
- .17 one set of fishing tackle;
- .18 a food ration totalling not less than 10,000 kJ for each person the liferaft is permitted to accommodate; these rations shall be kept in airtight packaging and be stowed in a watertight container;
- .19 watertight receptacles containing a total of 1.5 litres of fresh water for each person the liferaft is permitted to accommodate, of which 0.5 litres per person may be replaced by a de-salting apparatus capable of producing an equal amount of fresh water in 2 days;
- .20 one rustproof graduate drinking vessel;
- .21 six doses of anti-seasickness medicine and one seasickness bag for each person the liferaft is permitted to accommodate;

- .22 instructions on how to survive;
- .23 instructions for immediate action;
- .24 thermal protective aids complying with the requirements of regulation 34 sufficient for 10% of the number of persons the liferaft is permitted to accommodate or two, whichever is the greater.

5.2 The marking required by regulations 39.7.3.5 and 40.7.7 on liferafts equipped in accordance with paragraph 5.1 shall be "SOLAS A PACK" in block capitals of the Roman alphabet.

5.3 In the case of passenger ships engaged on short international voyages of such a nature and duration that, in the opinion of the Administration, not all the items specified in paragraph 5.1 are necessary, the Administration may allow the liferafts carried on any such ships to be provided with the equipment specified in paragraphs 5.1.1 to 5.1.6 inclusive, 5.1.8, 5.1.9, 5.1.13 to 5.1.16 inclusive and 5.1.21 to 5.1.24 inclusive and one half of the equipment specified in paragraphs 5.1.10 to 5.1.12 inclusive. The marking required by regulations 39.7.3.5 and 40.7.7 on such liferafts shall be "SOLAS B PACK" in block capitals of the Roman alphabet.

5.4 Where appropriate the equipment shall be stowed in a container which, if it is not an integral part of, or permanently attached to, the liferaft, shall be stowed and secured inside the liferaft and be capable of floating in water for at least 30 min without damage to its contents.

6 *Float-free arrangements for liferafts*

6.1 *Painter system*

The liferaft painter system shall provide a connection between the ship and the liferaft and shall be so arranged as to ensure that the liferaft when released and, in the case of an inflatable liferaft, inflated is not dragged under by the sinking ship.

6.2 *Weak link*

If a weak link is used in the float-free arrangement, it shall:

- .1 not be broken by the force required to pull the painter from the liferaft container;
- .2 if applicable, be of sufficient strength to permit the inflation of the liferaft;
- .3 break under a strain of 2.2 ± 0.4 kN.

6.3 *Hydrostatic release units*

If a hydrostatic release unit is used in the float-free arrangements, it shall:

- .1 be constructed of compatible materials so as to prevent malfunction of the unit Galvanizing or other forms of metallic coating on parts of the hydrostatic release unit shall not be accepted;
- .2 automatically release the liferaft at a depth of not more than 4 m;
- .3 have drains to prevent the accumulation of water in the hydrostatic chamber when the unit is in its normal position;
- .4 be so constructed as to prevent release when seas wash over the unit;
- .5 be permanently marked on its exterior with its type and serial number;
- .6 be provided with a document or identification plate stating the date of manufacture, type and serial number;
- .7 be such that each part connected to the painter system has a strength of not less than that required for the painter.

Regulation 39

Inflatable liferafts

1 Inflatable liferafts shall comply with the requirements of regulation 38 and, in addition, shall comply with the requirements of this regulation.

2 Construction of inflatable liferafts

2.1 The main buoyancy chamber shall be divided into not less than two separate compartments, each inflated through a non-return inflation valve on each compartment. The buoyancy chambers shall be so arranged that, in the event of any one of the compartments being damaged or failing to inflate, the intact compartments shall be able to support, with positive freeboard over the liferaft's entire periphery, the number of persons which the liferaft is permitted to accommodate, each having a mass of 75 kg and seated in their normal positions.

2.2 The floor of the liferaft shall be waterproof and shall be capable of being sufficiently insulated against cold either:

- .1 by means of one or more compartments that the occupants can inflate, or which inflate automatically and can be deflated and reinflated by the occupants; or
- .2 by other equally efficient means not dependent on inflation.

2.3 The liferaft shall be inflated with a non-toxic gas. Inflation shall be completed within a period of 1 min at an ambient temperature of between 18°C and 20°C and within a period of 3 min at an ambient temperature of — 30°C. After inflation the liferaft shall maintain its form when loaded with its full complement of persons and equipment.

2.4 Each inflatable compartment shall be capable of withstanding a pressure equal to at least 3 times the working pressure and shall be prevented from reaching a pressure exceeding twice the working pressure either by means of relief valves or by a limited gas supply. Means shall be provided for fitting the topping-up pump or bellows required by paragraph 10.1.2 so that the working pressure can be maintained.

3 Carrying capacity of inflatable liferafts

The number of persons which a liferaft shall be permitted to accommodate shall be equal to the lesser of:

- .1 the greatest whole number obtained by dividing by 0.096 the volume, measured in cubic metres of the main buoyancy tubes (which for this purpose shall include neither the arches nor the thwarts if fitted) when inflated; or
- .2 the greatest whole number obtained by dividing by 0.372 the inner horizontal cross-sectional area of the liferaft measured in square metres (which for this purpose may include the thwart or thwarts, if fitted) measured to the innermost edge of the buoyancy tubes; or
- .3 the number of persons having an average mass of 75 kg, all wearing lifejackets, that can be seated with sufficient comfort and headroom without interfering with the operation of any of the liferaft's equipment.

4 Access into inflatable liferafts

4.1 At least one entrance shall be fitted with a semi-rigid boarding ramp to enable persons to board the liferaft from the sea so arranged as to prevent significant deflation of the liferaft if the ramp is damaged. In the case of a davit-launched liferaft having more than one entrance, the boarding ramp shall be fitted at the entrance opposite the bowing lines and embarkation facilities.

4.2 Entrances not provided with a boarding ramp shall have a boarding ladder, the lowest step of which shall be situated not less than 0.4 m below the liferaft's light waterline.

4.3 There shall be means inside the liferaft to assist persons to pull themselves into the liferaft from the ladder.

5 *Stability of inflatable liferafts*

5.1 Every inflatable liferaft shall be so constructed that, when fully inflated and floating with the canopy uppermost, it is stable in a seaway.

5.2 The stability of the liferaft when in the inverted position shall be such that it can be righted in a seaway and in calm water by one person.

5.3 The stability of the liferaft when loaded with its full complement of persons and equipment shall be such that it can be towed at speeds of up to 3 knots in calm water.

6 *Inflatable liferaft fittings*

6.1 The breaking strength of the painter system including its means of attachment to the liferaft, except the weak link required by regulation 38.6, shall be not less than 10.0 kN for a liferaft permitted to accommodate nine persons or more, and not less than 7.5 kN for any other liferaft. The liferaft shall be capable of being inflated by one person.

6.2 A manually controlled lamp visible on a dark night with a clear atmosphere at a distance of at least 2 miles for a period of not less than 12 h shall be fitted to the top of the liferaft canopy. If the light is a flashing light it shall flash at a rate of not less than 50 flashes per minute for the first 2 h of operation of the 12 h operating period. The lamp shall be powered by a sea-activated cell or a dry chemical cell and shall light automatically when the liferaft inflates. The cell shall be of a type that does not deteriorate due to damp or humidity in the stowed liferaft.

6.3 A manually controlled lamp shall be fitted inside the liferaft capable of continuous operation for a period of at least 12 h. It shall light automatically when the liferaft inflates and be of sufficient intensity to enable reading of survival and equipment instructions.

7 *Containers for inflatable liferafts*

7.1 The liferaft shall be packed in a container that is:

- .1 so constructed as to withstand hard wear under conditions encountered at sea;
- .2 of sufficient inherent buoyancy, when packed with the liferaft and its equipment, to pull the painter from within and to operate the inflation mechanism should the ship sink;
- .3 as far as practicable watertight, except for drain holes in the container bottom.

7.2 The liferaft shall be packed in its container in such a way as to ensure, as far as possible, that the waterborne liferaft inflates in an upright position on breaking free from its container.

7.3 The container shall be marked with:

- .1 maker's name or trade mark;
- .2 serial number;
- .3 name of approved authority and the number of persons it is permitted to carry;
- .4 SOLAS;
- .5 type of emergency pack enclosed;
- .6 date when last serviced;
- .7 length of painter;

.8 maximum permitted height of stowage above waterline (depending on drop-test height and length of painter);

.9 launching instructions.

8 *Markings on inflatable liferafts*

The liferaft shall be marked with:

.1 maker's name or trade mark;

.2 serial number;

.3 date of manufacture (month and year);

.4 name of approving authority;

.5 name and place of servicing station where it was last serviced;

.6 number of persons it is permitted to accommodate over each entrance in characters not less than 100 mm in height of a colour contrasting with that of the liferaft.

9 *Davit-launched inflatable liferafts*

9.1 In addition to complying with the above requirements, a liferaft for use with an approved launching appliance shall, when suspended from its lifting hook or bridle, withstand a load of:

.1 4 times the mass of its full complement of persons and equipment, at an ambient temperature and a stabilized liferaft temperature of $20 \pm 3^{\circ}\text{C}$ with all relief valves inoperative; and

.2 1.1 times the mass of its full complement of persons and equipment at an ambient temperature and a stabilized liferaft temperature of -30°C with all relief valves operative.

9.2 Rigid containers for liferafts to be launched by a launching appliance shall be so secured that the container or parts of it are prevented from falling into the sea during and after inflation and launching of the contained liferaft.

10 *Additional equipment for inflatable liferafts*

10.1 In addition to the equipment required by regulation 38.5, every inflatable liferaft shall be provided with:

.1 one repair outfit for repairing punctures in buoyancy compartments;

.2 one topping-up pump or bellows.

10.2 The knives required by regulation 38.5.1.2 shall be safety knives.

Regulation 40

Rigid liferafts

1 Rigid liferafts shall comply with the requirements of regulation 38 and, in addition, shall comply with the requirements of this regulation.

2 *Construction of rigid liferafts*

2.1 The buoyancy of the liferaft shall be provided by approved inherently buoyant material placed as near as possible to the periphery of the liferaft. The buoyant material shall be fire-retardant or be protected by a fire-retardant covering.

2.2 The floor of the liferaft shall prevent the ingress of water and shall effectively support the occupants out of the water and insulate them from cold.

3 *Carrying capacity of rigid liferafts*

The number of persons which a liferaft shall be permitted to accommodate shall be equal to the lesser of:

- .1 the greatest whole number obtained by dividing by 0.096 the volume, measured in cubic metres of the buoyancy material multiplied by a factor of 1 minus the specific gravity of that material; or
- .2 the greatest whole number obtained by dividing by 0.372 the horizontal cross-sectional area of the floor of the liferaft measured in square metres; or
- .3 the number of persons having an average mass of 75 kg, all wearing lifejackets, that can be seated with sufficient comfort and headroom without interfering with the operation of any of the liferaft's equipment.

4 *Access into rigid liferafts*

4.1 At least one entrance shall be fitted with a rigid boarding ramp to enable persons to board the liferaft from the sea. In the case of a davit-launched liferaft having more than one entrance, the boarding ramp shall be fitted at the entrance opposite to the bowing and embarkation facilities.

4.2 Entrances not provided with a boarding ramp shall have a boarding ladder, the lowest step of which shall be situated not less than 0.4 m below the liferaft's light waterline.

4.3 There shall be means inside the liferaft to assist persons to pull themselves into the liferaft from the ladder.

5 *Stability of rigid liferafts*

5.1 Unless the liferaft is capable of operating safely whichever way up it is floating, its strength and stability shall be such that it is either self-righting or can be readily righted in a seaway and in calm water by one person.

5.2 The stability of a liferaft when loaded with its full complement of persons and equipment shall be such that it can be towed at speeds of up to 3 knots in calm water.

6 *Rigid liferaft fittings*

6.1 The liferaft shall be fitted with an efficient painter. The breaking strength of the painter system, including its means of attachment to the liferaft, except the weak link required by regulation 38.6, shall be not less than 10.0 kN for liferafts permitted to accommodate nine persons or more, and not less than 7.5 kN for any other liferaft.

6.2 A manually controlled lamp visible on a dark night with a clear atmosphere at a distance of at least 2 miles for a period of not less than 12 h shall be fitted to the top of the liferaft canopy. If the light is a flashing light it shall flash at a rate of not less than 50 flashes per minute for the first 2 h of operation of the 12 h operating period. The lamp shall be powered by a sea-activated cell or a dry chemical cell and shall light automatically when the liferaft canopy is set in place. The cell shall be of a type that does not deteriorate due to damp or humidity in the stowed liferaft.

6.3 A manually controlled lamp shall be fitted inside the liferaft, capable of continuous operation for a period of at least 12 h. It shall light automatically when the canopy is set in place and be of sufficient intensity to enable reading of survival and equipment instructions.

7 *Markings on rigid liferafts*

The liferaft shall be marked with:

- .1 name and port of registry of the ship to which it belongs;
- .2 maker's name or trade mark;
- .3 serial number;
- .4 name of approving authority;

- .5 number of persons it is permitted to accommodate over each entrance in characters not less than 100 mm in height of a colour contrasting with that of the liferaft;
- .6 SOLAS;
- .7 type of emergency pack enclosed;
- .8 length of painter;
- .9 maximum permitted height of stowage above waterline (drop-test height);
- .10 launching instructions.

8 *Davit-launched rigid liferafts*

In addition to the above requirements, a rigid liferaft for use with an approved launching appliance shall, when suspended from its lifting hook or bridle, withstand a load of 4 times the mass of its full complement of persons and equipment.

Regulation 41

General requirements for lifeboats

1 *Construction of lifeboats*

1.1 All lifeboats shall be properly constructed and shall be of such form and proportions that they have ample stability in a seaway and sufficient freeboard when loaded with their full complement of persons and equipment. All lifeboats shall have rigid hulls and shall be capable of maintaining positive stability when in an upright position in calm water and loaded with their full complement of persons and equipment and holed in any one location below the waterline, assuming no loss of buoyancy material and no other damage.

1.2 All lifeboats shall be of sufficient strength to:

- .1 enable them to be safely lowered into the water when loaded with their full complement of persons and equipment; and
- .2 be capable of being launched and towed when the ship is making headway at a speed of 5 knots in calm water.

1.3 Hulls and rigid covers shall be fire-retardant or non-combustible.

1.4 Seating shall be provided on thwarts, benches or fixed chairs fitted as low as practicable in the lifeboat and constructed so as to be capable of supporting the number of persons each weighing 100 kilograms for which spaces are provided in compliance with the requirements of paragraph 2.2.2.

1.5 Each lifeboat shall be of sufficient strength to withstand a load, without residual deflection on removal of that load:

- .1 in the case of boats with metal hulls, 1.25 times the total mass of the lifeboat when loaded with its full complement of persons and equipment; or
- .2 in the case of other boats, twice the total mass of the lifeboat when loaded with its full complement of persons and equipment.

1.6 Each lifeboat shall be of sufficient strength to withstand, when loaded with its full complement of persons and equipment and with, where applicable, skates or fenders in position, a lateral impact against the ship's side at an impact velocity of at least 3.5 m/s and also a drop into the water from a height of at least 3 m.

1.7 The vertical distance between the floor surface and the interior of the enclosure or canopy over 50 % of the floor area shall be:

- .1 not less than 1.3 metres for a lifeboat permitted to accommodate nine persons or less;
- .2 not less than 1.7 metres for a lifeboat permitted to accommodate 24 persons or more;

3 not less than the distance as determined by linear interpolation between 1.3 metres and 1.7 metres for a lifeboat permitted to accommodate between nine and 24 persons.

2 Carrying capacity of lifeboats

2.1 No lifeboat shall be approved to accommodate more than 150 persons.

2.2 The number of persons which a lifeboat shall be permitted to accommodate shall be equal to the lesser of:

- 1 the number of persons having an average mass of 75 kilograms, all wearing lifejackets, that can be seated in a normal position without interfering with the means of propulsion or the operation of any of the lifeboat's equipment; or
- 2 the number of spaces that can be provided on the seating arrangements in accordance with Figure 1. The shapes may be overlapped as shown, provided footrests are fitted and there is sufficient room for legs and the vertical separation between the upper and lower seat is not less than 350 millimetres.

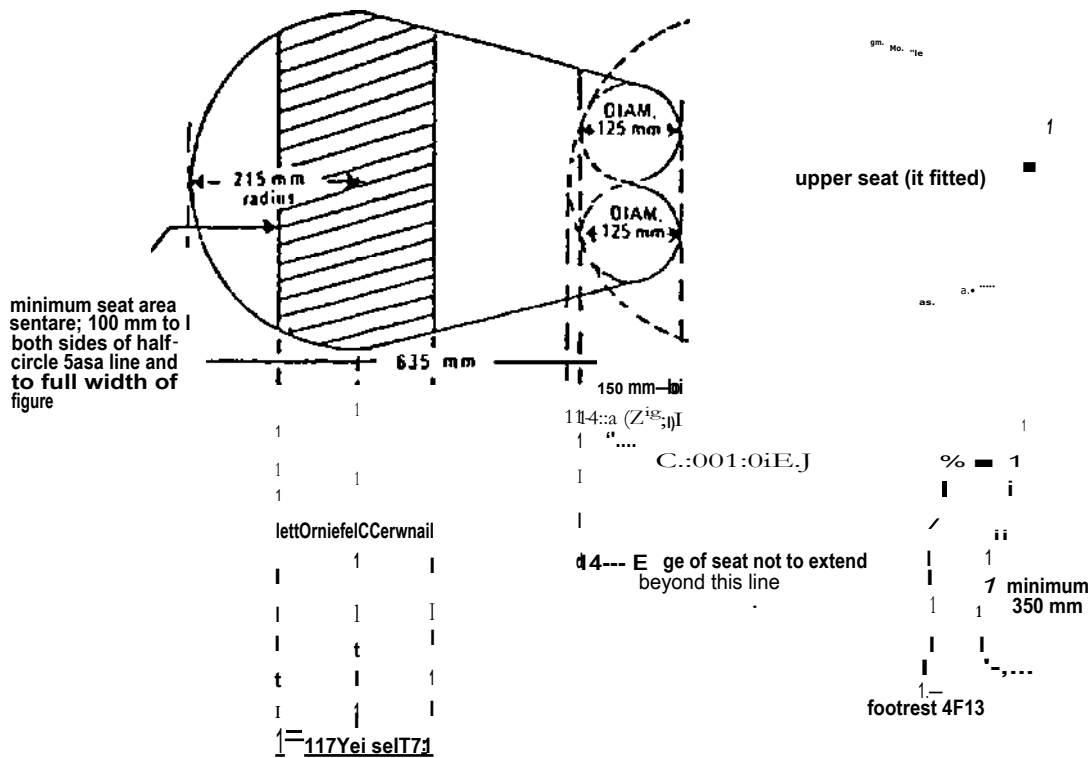

Figure 1

2.3 Each seating position shall be clearly indicated in the lifeboat.

3 Access into lifeboats

3.1 Every passenger ship lifeboat shall be so arranged that it can be rapidly boarded by its full complement of persons. Rapid disembarkation shall also be possible.

3.2 Every cargo ship lifeboat shall be so arranged that it can be boarded by its full complement of persons in not more than 3 min from the time the instruction to board is given. Rapid disembarkation shall also be possible.

3.3 Lifeboats shall have a boarding ladder than can be used on either side of the lifeboat to enable persons in the water to board the lifeboat. The lowest step of the ladder shall be not less than 0.4 m below the lifeboat's light waterline.

3.4 The lifeboat shall be so arranged that helpless people can be brought on board either from the sea or on stretchers.

3.5 All surfaces on which persons might walk shall have a non-skid finish.

4 Lifeboat buoyancy

All lifeboats shall have inherent buoyancy or shall be fitted with inherently buoyant material which shall not be adversely affected by seawater, oil or oil products, sufficient to float the lifeboat with all its equipment on board when flooded and open to the sea. Additional inherently buoyant material, equal to 280 N of buoyant force per person shall be provided for the number of persons the lifeboat is permitted to accommodate. Buoyant material, unless in addition to that required above, shall not be installed external to the hull of the lifeboat.

5 Lifeboat freeboard and stability

All lifeboats, when loaded with 50% of the number of persons the lifeboat is permitted to accommodate seated in their normal positions to one side of the centreline, shall have a freeboard, measured from the waterline to the lowest opening through which the lifeboat may become flooded, of at least 1.5% of the lifeboat's length or 100 mm, whichever is the greater.

6 Lifeboat propulsion

6.1 Every lifeboat shall be powered by a compression ignition engine. No engine shall be used for any lifeboat if its fuel has a flashpoint of 43°C or less (closed cup test).

6.2 The engine shall be provided with either a manual starting system, or a power starting system with two independent rechargeable energy sources. Any necessary starting aids shall also be provided. The engine starting systems and starting aids shall start the engine at an ambient temperature of — 15°C within 2 min of commencing the start procedure unless, in the opinion of the Administration having regard to the particular voyages in which the ship carrying the lifeboat is constantly engaged, a different temperature is appropriate. The starting systems shall not be impeded by the engine casing, thwarts or other obstructions.

6.3 The engine shall be capable of operating for not less than 5 min after starting from cold with the lifeboat out of the water.

6.4 The engine shall be capable of operating when the lifeboat is flooded up to the centreline of the crank shaft.

6.5 The propeller shafting shall be so arranged that the propeller can be disengaged from the engine. Provision shall be made for ahead and astern propulsion of the lifeboat.

6.6 The exhaust pipe shall be so arranged as to prevent water from entering the engine in normal operation:

6.7 All lifeboats shall be designed with due regard to the safety of persons in the water and to the possibility of damage to the propulsion system by floating debris.

6.8 The speed of a lifeboat when proceeding ahead in calm water, when loaded with its full complement of persons and equipment and with all engine-powered auxiliary equipment in operation, shall be at least 6 knots and at least 2 knots when towing a 25-person liferaft loaded with its full complement of persons and equipment or its equivalent. Sufficient fuel, suitable for use throughout the temperature range expected in the area in which the ship operates, shall be provided to run the fully loaded lifeboat at 6 knots for a period of not less than 24 h.

6.9 The lifeboat engine, transmission and engine accessories shall be enclosed in a fire-retardant casing or other suitable arrangements providing similar protection. Such arrangements shall also protect persons from coming into accidental contact with hot or moving parts and protect the engine from exposure to weather and sea. Adequate means shall be provided to reduce the engine noise. Starter batteries shall be provided with casings which form a watertight enclosure around the bottom and sides of the batteries. The battery casings shall have a tight fitting top which provides for necessary gas venting.

6.10 The lifeboat engine and accessories shall be designed to limit electromagnetic emissions so that engine operation does not interfere with the operation of radio life-saving appliances used in the lifeboat.

6.11 Means shall be provided for recharging all engine-starting, radio and search-light batteries. Radio batteries shall not be used to provide power for engine starting. Means shall be provided for recharging lifeboat batteries from the ship's power supply at a supply voltage not exceeding 55 V which can be disconnected at the lifeboat embarkation station.

6.12 Water-resistant instructions for starting and operating the engine shall be provided and mounted in a conspicuous place near the engine starting controls.

7 Lifeboat fittings

7.1 All lifeboats shall be provided with at least one drain valve fitted near the lowest point in the hull, which shall automatically open to drain water from the hull when the lifeboat is not waterborne and shall automatically close to prevent entry of water when the lifeboat is waterborne. Each drain valve shall be provided with a cap or plug to close the valve, which shall be attached to the lifeboat by a lanyard, a chain, or other suitable means. Drain valves shall be readily accessible from inside the lifeboat and their position shall be clearly indicated.

7.2 All lifeboats shall be provided with a rudder and tiller. When a wheel or other remote steering mechanism is also provided the tiller shall be capable of controlling the rudder in case of failure of the steering mechanism. The rudder shall be permanently attached to the lifeboat. The tiller shall be permanently installed on, or linked to, the rudder stock; however, if the lifeboat has a remote steering mechanism, the tiller may be removable and securely stowed near the rudder stock. The rudder and tiller shall be so arranged as not to be damaged by operation of the release mechanism or the propellor.

7.3 Except in the vicinity of the rudder and propellor, a buoyant lifeline shall be becketed around the outside of the lifeboat.

7.4 Lifeboats which are not self-righting when capsized shall have suitable hand-holds on the underside of the hull to enable persons to cling to the lifeboat. The handholds shall be fastened to the lifeboat in such a way that, when subjected to an impact sufficient to cause them to break away from the lifeboat, they break away without damaging the lifeboat.

7.5 All lifeboats shall be fitted with sufficient watertight lockers or compartments to provide for the storage of the small items of equipment, water and provisions required by paragraph 8. Means shall be provided for the storage of collected rainwater.

7.6 Every lifeboat to be launched by a fall or falls shall be fitted with a release mechanism complying with the following requirements:

- .1 The mechanism shall be so arranged that all hooks are released simultaneously.
- .2 The mechanism shall have two release capabilities as follows:
 - .2.1 a normal release capability which will release the lifeboat when it is waterborne or when there is no load on the hooks;
 - .2.2 an on-load release capability which will release the lifeboat with a load on the hooks. This release shall be so arranged as to release the lifeboat under any conditions of loading from no-load with the lifeboat water-borne to a load of 1.1 times the total mass of the lifeboat when loaded with its full complement of persons and equipment. This release capability shall be adequately protected against accidental or premature use.

- .3 The release control shall be clearly marked in a colour that contrasts with its surroundings.
- .4 The mechanism shall be designed with a factor of safety of 6 based on the ultimate strength of the materials used, assuming the mass of the lifeboat is equally distributed between the falls.

7.7 Every lifeboat shall be fitted with a release device to enable the forward painter to be released when under tension.

7.8 Every lifeboat shall be provided with a permanently installed earth connection and arrangements for adequately siting and securing in the operating position the antenna provided with the portable radio apparatus required by regulation 6.2.1.

7.9 Lifeboats intended for launching down the side of a ship shall have skates and fenders as necessary to facilitate launching and prevent damage to the lifeboat.

7.10 A manually controlled lamp visible on a dark night with a clear atmosphere at a distance of at least 2 miles for a period of not less than 12 h shall be fitted to the top of the cover or enclosure. If the light is a flashing light, it shall initially flash at a rate of not less than 50 flashes per minute over the first 2 h of operation of the 12 h operating period.

7.11 A lamp or source of light shall be fitted inside the lifeboat to provide illumination for not less than 12 h to enable reading of survival and equipment instructions; however, oil lamps shall not be permitted for this purpose.

7.12 Unless expressly provided otherwise, every lifeboat shall be provided with effective means of bailing or be automatically self-bailing.

7.13 Every lifeboat shall be so arranged that an adequate view forward, aft and to both sides is provided from the control and steering position for safe launching and manoeuvring.

8 *Lifeboat equipment*

All items of lifeboat equipment, whether required by this paragraph or elsewhere in this chapter, with the exception of boat-hooks which shall be kept free for fending off purposes, shall be secured within the lifeboat by lashings, storage in lockers or compartments, storage in brackets or similar mounting arrangements or other suitable means. The equipment shall be secured in such a manner as not to interfere with any abandonment procedures. All items of lifeboat equipment shall be as small and of as little mass as possible and shall be packed in a suitable and compact form. Except where otherwise stated, the normal equipment of every lifeboat shall consist of:

- .1 sufficient buoyant oars to make headway in calm seas. Thole pins, crutches or equivalent arrangements shall be provided for each oar provided. Those pins or crutches shall be attached to the boat by lanyards or chains;
- .2 tow boat-hooks;
- .3 a buoyant bailer and two buckets;
- .4 a survival manual;
- .5 a binnacle containing an efficient compass which is luminous or provided with suitable means of illumination. In a totally enclosed lifeboat, the binnacle shall be permanently fitted at the steering position; in any other lifeboat, it shall be provided with suitable mounting arrangements;
- .6 a sea-anchor of adequate size fitted with a shock-resistant hawser and a tripping line which provides a firm hand grip when wet. The strength of the sea-anchor, hawser and tripping line shall be adequate for all sea conditions;
- .7 two efficient painters of a length equal to not less than twice the distance from the stowage position of the lifeboat to the waterline in the lightest seagoing condition or 15 m, whichever is the greater. One painter attached to the release device required by regulation 41.7.7 shall be placed at the forward end of the lifeboat and the other shall be firmly secured at or near the bow of the lifeboat ready for use;
- .8 two hatchets, one at each end of the lifeboat;

- .9 watertight receptacles containing a total of 3 litres of fresh water for each person the lifeboat is permitted to accommodate, of which 1 litre per person may be replaced by a de-salting apparatus capable of producing an equal amount of fresh water in 2 days;
- .10 a rustproof dipper with lanyard;
- .11 a rustproof graduated drinking vessel;
- .12 a food ration totalling not less than 10,000 kJ for each person the lifeboat is permitted to accommodate; these rations shall be kept in airtight packaging and be stowed in a watertight container;
- .13 four rocket parachute flares complying with the requirements of regulations 35;
- .14 six hand flares complying with the requirements of regulation 36;
- .15 two buoyant smoke signals complying with the requirements of regulation 37;
- .16 one waterproof electric torch suitable for Morse signalling together with one spare set of batteries and one spare bulb in a waterproof container;
- .17 one daylight signalling mirror with instructions for its use for signalling to ships and aircraft;
- .18 one copy of the life-saving signals prescribed by regulation V/16 on a waterproof card or in a waterproof container;
- .19 one whistle or equivalent sound signal;
- .20 a first-aid outfit in a waterproof case capable of being closed tightly after use;
- .21 six doses of anti-seasickness medicine and one seasickness bag for each person;
- .22 a jack-knife to be kept attached to the boat by a lanyard;
- .23 three tin openers;
- .24 two buoyant rescue quoits, attached to not less than 30 m of buoyant line;
- .25 a manual pump;
- .26 one set of fishing tackle
- .27 sufficient tools for minor adjustments to the engine and its accessories;
- .28 portable fire-extinguishing equipment suitable for extinguishing oil fires;
- .29 a searchlight capable of effectively illuminating a light-coloured object at night having a width of 18 m at a distance of 180 m for a total period of 6 h and of working for not less than 3 h continuously;
- .30 an efficient radar reflector;
- .31 thermal protective aids complying with the requirements of regulation 34 sufficient for 10% of the number of persons the lifeboat is permitted to accommodate or two, whichever is the greater.
- .32 In the case of ships engaged on voyages of such a nature and duration that, in the opinion of the Administration, the items specified in paragraphs 8.12 and 8.26 are unnecessary, the Administration may allow these items to be dispensed with.

9 *Lifeboat markings*

9.1 The dimensions of the lifeboat and the number of persons which it is permitted to accommodate shall be marked on it in clear permanent characters.

9.2 The name and port of registry of the ship to which the lifeboat belongs shall be marked on each side of the lifeboat's bow in block capitals of the Roman alphabet.

9.3 Means of identifying the ship to which the lifeboat belongs and the number of the lifeboat shall be marked in such a way that they are visible from above.

Regulation 42

Partially enclosed lifeboats

1 Partially enclosed lifeboats shall comply with the requirements of regulation 41 and in addition shall comply with the requirements of this regulation.

2 Every partially enclosed lifeboat shall be provided with effective means of bailing or be automatically self-bailing.

3 Partially enclosed lifeboats shall be provided with permanently attached rigid covers extending over not less than 20% of the length of the lifeboat from the stem and not less than 20% of the length of the lifeboat from the aftermost part of the lifeboat. The lifeboat shall be fitted with a permanently attached foldable canopy which together with the rigid covers completely encloses the occupants of the lifeboat in a weatherproof shelter and protects them from exposure. The canopy shall be so arranged that:

- .1 it is provided with adequate rigid sections or battens to permit erection of the canopy;
- .2 it can be easily erected by not more than two persons;
- .3 it is insulated to protect the occupants against heat and cold by means of not less than two layers of material separated by an air gap or other equally efficient means; means shall be provided to prevent accumulation of water in the air gap;
- .4 its exterior is of a highly visible colour and its interior is of a colour which does not cause discomfort to the occupants;
- .5 it has entrances at both ends and on each side, provided with efficient adjustable closing arrangements which can be easily and quickly opened and closed from inside or outside so as to permit ventilation but exclude seawater, wind and cold; means shall be provided for holding the entrances securely in the open and closed position;
- .6 with the entrances closed, it admits sufficient air for the occupants at all times;
- .7 it has means for collecting rainwater;
- .8 the occupants can escape in the event of the lifeboat capsizing.

4 The interior of the lifeboat shall be of a highly visible colour.

5 The radiotelegraph installation required by regulation 6.2.2 shall be installed in a cabin large enough to accommodate both the equipment and the person using it. No separate cabin is required if the construction of the lifeboat provides a sheltered space to the satisfaction of the Administration.

Regulation 43

Self-righting partially enclosed lifeboats

1 Self-righting partially enclosed lifeboats shall comply with the requirements of regulation 41 and in addition shall comply with the requirements of this regulation.

2 *Enclosure*

2.1 Permanently attached rigid covers shall be provided extending over not less than 20% of the length of the lifeboat from the stem and not less than 20% of the length of the lifeboat from the aftermost part of the lifeboat.

2.2 The rigid covers shall form two shelters. If the shelters have bulkheads they shall have openings of sufficient size to permit easy access by persons each wearing an immersion suit or warm clothes and a lifejacket. The interior height of the shelters shall be sufficient to permit persons easy access to their seats in the bow and stern of the lifeboat.

2.3 The rigid covers shall be so arranged that they include windows or translucent panels to admit sufficient daylight to the inside of the lifeboat with the openings or canopies so as to make artificial light unnecessary.

2.4 The rigid covers shall have railings to provide a secure handhold for persons moving about the exterior of the lifeboat.

2.5 Open parts of the lifeboat shall be fitted with a permanently attached foldable canopy so arranged that:

- .1 it can be easily erected by not more than two persons in not more than 2 min;
- .2 it is insulated to protect the occupants against cold by means of not less than two layers of material separated by an air gap or other equally efficient means.

2.6 The enclosure formed by the rigid covers and canopy shall be so arranged:

- .1 as to allow launching and recovery operations to be performed without any occupant having to leave the enclosure;
- .2 that it has entrances at both ends and on each side, provided with efficient adjustable closing arrangements which can be easily and quickly opened and closed from inside or outside so as to permit ventilation but exclude seawater, wind and cold; means shall be provided for holding the entrances securely in the open and in the closed position;
- .3 that with the canopy erected and all entrances closed, sufficient air is admitted for the occupants at all times;
- .4 that it has means for collecting rainwater;
- .5 that the exterior of the rigid covers and canopy and the interior of that part of the lifeboat covered by the canopy is of a highly visible colour. The interior of the shelters shall be of a colour which does not cause discomfort to the occupants;
- .6 that it is possible to row the lifeboat.

3 *Capsizing and re-righting*

3.1 A safety belt shall be fitted at each indicated seating position. The safety belt shall be so designed as to hold a person of a mass of 100 kg securely in place when the lifeboat is in a capsized position.

3.2 The stability of the lifeboat shall be such that it is inherently or automatically self-righting when loaded with its full or a partial complement of persons and equipment and the persons are secured with safety belts.

4. *Propulsion*

4.1 The engine and transmission shall be controlled from the helmsman's position.

4.2 The engine and engine installation shall be capable of running in any position during capsize and continue to run after the lifeboat returns to the upright or shall automatically stop on capsizing and be easily restarted after the lifeboat returns to the upright and the water has been drained from the lifeboat. The design of the fuel and lubricating systems shall prevent the loss of fuel and the loss of more than 250 ml of lubricating oil from the engine during capsize.

4.3 Air-cooled engines shall have a duct system to take in cooling air from, and exhaust it to, the outside of the lifeboat. Manually operated dampers shall be provided to enable cooling air to be taken in from, and exhausted to, the interior of the lifeboat.

5 *Construction and fendering*

5.1 Notwithstanding regulation 41.1.6, a self-righting partially enclosed lifeboat shall be so constructed and fendered as to ensure that the lifeboat renders protection against harmful accelerations resulting from an impact of the lifeboat, when loaded with its full complement of persons and equipment, against the ship's side at an impact velocity of not less than 3.5 m/s.

5.2 The lifeboat shall be automatically self-bailing.

Regulation 44

Totally enclosed lifeboats

1 Totally enclosed lifeboats shall comply with the requirements of regulation 41 and in addition shall comply with the requirements of this regulation.

2 *Enclosure*

Every totally enclosed lifeboat shall be provided with a rigid watertight enclosure which completely encloses the lifeboat. The enclosure shall be so arranged that:

- .1 it protects the occupants against the heat and cold;
- .2 access to the lifeboat is provided by hatches which can be closed to make the lifeboat watertight;
- .3 hatches are positioned so as to allow launching and recovery operations to be performed without any occupant having to leave the enclosure;
- .4 access hatches are capable of being opened and closed from both inside and outside and are equipped with means to hold them securely in open positions;
- .5 it is possible to row the lifeboat;
- .6 it is capable, when the lifeboat is in the capsized position with the hatches closed and without significant leakage, of supporting the entire mass of the lifeboat, including all equipment, machinery and its full complement of persons;
- .7 it includes windows or translucent panels on both sides which admit sufficient daylight to the inside of the lifeboat with the hatches closed to make artificial light unnecessary;
- .8 its exterior is of a highly visible colour and its interior of a colour which does not cause discomfort to the occupants;
- .9 handrails provide a secure handhold for persons moving about the exterior of the lifeboat, and aid embarkation and disembarkation;
- .10 persons have access to their seats from an entrance without having to climb over thwarts or other obstructions;
- .11 the occupants are protected from the effects of dangerous subatmospheric pressures which might be created by the lifeboat's engine.

3 *Capsizing and re-righting*

3.1 A safety belt shall be fitted at each indicated seating position. The safety belt shall be designed to hold a person of a mass of 100 kg securely in place when the lifeboat is in a capsized position.

3.2 The stability of the lifeboat shall be such that it is inherently or automatically self-righting when loaded with its full or a partial complement of persons and equipment and all entrances and openings are closed watertight and the persons are secured with safety belts.

3.3 The lifeboat shall be capable of supporting its full complement of persons and equipment when the lifeboat is in the damaged condition prescribed in regulation 41.1.1 and its stability shall be such that in the event of capsizing, it will automatically attain a position that will provide an above-water escape for its occupants.

3.4 The design of all engine exhaust pipes, air ducts and other openings shall be such that water is excluded from the engine when the lifeboat capsizes and re-rights.

4 *Propulsion*

4.1 The engine and transmission shall be controlled from the helmsman's position.

4.2 The engine and engine installation shall be capable of running in any position during capsize and continue to run after the lifeboat returns to the upright or shall automatically stop on capsizing and be easily restarted after the lifeboat returns to the upright. The design of the fuel and lubricating systems shall prevent the loss of fuel and the loss of more than 250 ml of lubricating oil from the engine during capsize.

4.3 Air cooled engines shall have a duct system to take in cooling air from, and exhaust it to, the outside of the lifeboat. Manually operated dampers shall be provided to enable cooling air to be taken in from, and exhausted to, the interior of the lifeboat.

5 *Construction and fendering*

Notwithstanding regulation 41.1.6, a totally enclosed lifeboat shall be so constructed and fendered as to ensure that the lifeboat renders protection against harmful accelerations resulting from an impact of the lifeboat, when loaded with its full complement of persons and equipment, against the ship's side at an impact velocity of not less than 3.5 m/s.

6 *Free-fall lifeboats*

A lifeboat arranged for free-fall launching shall be so constructed that it is capable of rendering protection against harmful accelerations resulting from being launched, when loaded with its full complement of persons and equipment, from at least the maximum height at which it is designed to be stowed above the waterline with the ship in its lightest seagoing condition, under unfavourable conditions of trim of up to 10° and with the ship listed not less than 20° either way.

Regulation 45

Lifeboats with a self-contained air support system

In addition to complying with the requirements of regulations 41 and 44, a lifeboat with a self-contained air support system shall be so arranged that, when proceeding with all entrances and openings closed, the air in the lifeboat remains safe and breathable and the engine runs normally for a period of not less than 10 min. During this period the atmospheric pressure inside the lifeboat shall never fall below the outside atmospheric pressure nor shall it exceed it by more than 20 mbar. The system shall have visual indicators to indicate the pressure of the air supply at all times.

Regulation 46

Fire-protected lifeboats

1 In addition to complying with the requirements of regulations 41, 44 and 45, a fire-protected lifeboat when waterborne shall be capable of protecting the number of persons it is permitted to accommodate when subjected to a continuous oil fire that envelops the lifeboat for a period of not less than 8 min.

2 *Water spray system*

A lifeboat which has a water spray fire-protection system shall comply with the following:

- .1 water for the system shall be drawn from the sea by a self-priming motor pump. It shall be possible to turn "on" and "off" the flow of water over the exterior of the lifeboat;
- .2 the seawater intake shall be so arranged as to prevent the intake of flammable liquids from the sea surface;
- .3 the system shall be arranged for flushing with fresh water and allowing complete drainage.

SECTION V—RESCUE BOATS

Regulation 47

Rescue boats

1 *General requirements*

1.1 Except as provided by this regulation, all rescue boats shall comply with the requirements of regulations 41.1 to 41.7.4 inclusive and 41.7.6, 41.7.7, 41.7.9, 41.7.12 and 41.9.

1.2 Rescue boats may be either of rigid or inflated construction or a combination of both and shall:

- .1 be not less than 3.8 m and not more than 8.5 m in length;
- .2 be capable of carrying at least five seated persons and a person lying down.

1.3 Rescue boats which are a combination of rigid and inflated construction shall comply with the appropriate requirements of this regulation to the satisfaction of the Administration.

1.4 Unless the rescue boat has adequate sheer, it shall be provided with a bow cover extending for not less than 15% of its length.

1.5 Rescue boats shall be capable of manoeuvring at speeds up to 6 knots and maintaining that speed for a period of at least 4 h.

1.6 Rescue boats shall have sufficient mobility and manoeuvrability in a seaway to enable persons to be retrieved from the water, marshal liferafts and tow the largest liferaft carried on the ship when loaded with its full complement of persons and equipment or its equivalent at a speed of at least 2 knots.

1.7 A rescue boat shall be fitted with an inboard engine or outboard motor. If it is fitted with an outboard motor, the rudder and tiller may form part of the engine. Notwithstanding the requirements of regulation 41.6.1, petrol-driven outboard engines with an approved fuel system may be fitted in rescue boats provided the fuel tanks are specially protected against fire and explosion.

1.8 Arrangements for towing shall be permanently fitted in rescue boats and shall be sufficiently strong to marshal or tow liferafts as required by paragraph 1.6.

1.9 Rescue boats shall be fitted with weathertight stowage for small items of equipment.

2 *Rescue boat equipment*

2.1 All items of rescue boat equipment, with the exception of boat-hooks which shall be kept free for fending off purposes, shall be secured within the rescue boat by lashings, storage in lockers or compartments, storage in brackets or similar mounting arrangements, or other suitable means. The equipment shall be secured in such a manner as not to interfere with any launching or recovery procedures. All items of rescue boat equipment shall be as small and of as little mass as possible and shall be packed in suitable and compact form.

2.2 The normal equipment of every rescue boat shall consist of:

- .1 sufficient buoyant oars or paddles to make headway in calm seas. Thole pins, crutches or equivalent arrangements shall be provided for each oar. Thole pins or crutches shall be attached to the boat by lanyards or chains;
- .2 a buoyant bailer;
- .3 a binnacle containing an efficient compass which is luminous or provided with suitable means of illumination;
- .4 a sea-anchor and tripping line with a hawser of adequate strength not less than 10 m *in* length;
- .5 a painter of sufficient length and strength, attached to the release device complying with the requirements of regulation 41.7.7 and placed at the

forward end of the rescue boat;

- .6 one buoyant line, not less than 50 m in length, of sufficient strength to tow a liferaft as required by paragraph 1.6;
- .7 one waterproof electric torch suitable for Morse signalling, together with one spare set of batteries and one spare bulb in a waterproof container;
- .8 one whistle or equivalent sound signal;
- .9 a first-aid outfit in a waterproof case capable of being closed tightly after use;
- .10 two buoyant rescue quoits, attached to not less than 30 m of buoyant line;
- .11 a searchlight capable of effectively illuminating a light-coloured object at night having a width of 18 m at a distance of 180 m for a total period of 6 h and of working for at least 3 h continuously;
- .12 an effective radar reflector;
- .13 thermal protective aids complying with the requirements of regulation 34 sufficient for 10% of the number of persons the rescue boat is permitted to accommodate or two, whichever is the greater.

2.3 In addition to the equipment required by paragraph 2.2, the normal equipment of every rigid rescue boat shall include:

- .1 a boat hook;
- .2 a bucket;
- .3 a knife or hatchet.

2.4 In addition to the equipment required by paragraph 2.2 the normal equipment of every inflated rescue boat shall consist of:

- .1 a buoyant safety knife;
- .2 two sponges;
- .3 an efficient manually operated bellows or pump;
- .4 a repair kit in a suitable container for repairing punctures;
- .5 a safety boat-hook.

3 *Additional requirements for inflated rescue boats*

3.1 The requirements of regulations 41.1.3 and 41.1.5 do not apply to inflated rescue boats.

3.2 An inflated rescue boat shall be constructed in such a way that, when suspended by its bridle or lifting hook:

- .1 it is of sufficient strength and rigidity to enable it to be lowered and recovered with its full complement of persons and equipment;
- .2 it is of sufficient strength to withstand a load of 4 times the mass of its full complement of persons and equipment at an ambient temperature of $20 \pm 3^{\circ}\text{C}$ with all relief valves inoperative;
- .3 it is of sufficient strength to withstand a load of 1.1 times the mass of its full complement of persons and equipment at an ambient temperature of -30°C , with all relief valves operative.

3.3 Inflated rescue boats shall be so constructed as to be capable of withstanding exposure:

- .1 when stowed on an open deck on a ship at sea;
- .2 for 30 days afloat in all sea conditions.

3.4 In addition to complying with the requirements of regulation 41.9, inflated rescue boats shall be marked with a serial number, the maker's name or trade mark and the date of manufacture.

3.5 The buoyancy of an inflated rescue boat shall be provided by either a single tube subdivided into at least five separate compartments of approximately equal volume or two separate tubes neither exceeding 60% of the total volume. The buoyancy tubes shall be so arranged that, in the event of any one of the compartments being damaged, the intact compartments shall be able to support the number of persons which the rescue boat is

permitted to accommodate, each having a mass of 75 kg, when seated in their normal positions with positive freeboard over the rescue boat's entire periphery.

3.6 The buoyancy tubes forming the boundary of the inflated rescue boat shall on inflation provide a volume of not less than 0.17m³ for each person the rescue boat is permitted to accommodate.

3.7 Each buoyancy compartment shall be fitted with a non-return valve for manual inflation and means for deflation. A safety relief valve shall also be fitted unless the Administration is satisfied that such an appliance is unnecessary.

3.8 Underneath the bottom and on vulnerable places on the outside of the inflated rescue boat, rubbing strips shall be provided to the satisfaction of the Administration.

3.9 Where a transom is fitted it shall not be inset by more than 20% of the overall length of the rescue boat.

3.10 Suitable patches shall be provided for securing the painters fore and aft and the becketed lifelines inside and outside the boat.

3.11 The inflated rescue boat shall be maintained at all times in a fully inflated condition.

SECTION VI—LAUNCHING AND EMBARKATION APPLIANCES

Regulation 48

Launching and embarkation appliances

1 *General requirements*

1.1 Each launching appliance together with all its lowering and recovery gear shall be so arranged that the fully equipped survival craft or rescue boat it serves can be safely lowered against a trim of up to 10° and a list of up to 20° either way:

- .1 when boarded, as required by regulation 22 or 28, by its full complement of persons;
- .2 without persons in the survival craft or rescue boat.

1.2 Notwithstanding the requirements of paragraph 1.1, lifeboat launching appliances for oil tankers, chemical tankers and gas carriers with a final angle of heel greater than 20° calculated in accordance with the International Convention for the Prevention of Pollution from Ships, 1973, as modified by the 1978 Protocol related thereto and the recommendations of the Organization*, as applicable, shall be capable of operating at the final angle of heel on the lower side of the ship.

1.3 A launching appliance shall not depend on any means other than gravity or stored mechanical power which is independent of the ship's power supplies to launch the survival craft or rescue boat it serves in the fully loaded and equipped condition and also in the light condition.

1.4 A launching mechanism shall be so arranged that it may be actuated by one person from a position on the ship's deck, and from a position within the survival craft or rescue boat; the survival craft shall be visible to the person on deck operating the launching mechanism.

1.5 Each launching appliance shall be so constructed that a minimum amount of routine maintenance is necessary. All parts requiring regular maintenance by the ship's crew shall be readily accessible and easily maintained.

*Reference is made to the damage stability requirements of the International Code for the Construction and Equipment of Ships Carrying Dangerous Chemicals in Bulk (IBC Code) adopted by the Maritime Safety Committee by resolution MSC.4(48)¹ and the International Code for the Construction and Equipment of Ships carrying Liquefied Gases in Bulk (IGC Code) adopted by the Maritime Safety Committee by resolution (MSC.5(48))².

¹Treaty Series No. 13. Cm 3926.

²Treaty Series No. 15. Cm 3928.

1.6 The winch brakes of a launching appliance shall be of sufficient strength to withstand:

- .1 a static test with a proof load of not less than 1.5 times the maximum working load; and
- .2 a dynamic test with a proof load of not less than 1.1 times the maximum working load at maximum lowering speed.

1.7 The launching appliance and its attachments other than winch brakes shall be of sufficient strength to withstand a static proof load on test of not less than 2.2 times the maximum working load.

1.8 Structural members and all blocks, falls, padeyes, links, fastenings and all other fittings used in connection with launching equipment shall be designed with not less than a minimum factor of safety on the basis of the maximum working load assigned and the ultimate strength of the material used for construction. A minimum factor of safety of 4.5 shall be applied to all davit and winch structural members, and a minimum factor of safety of 6 shall be applied to falls, suspension chains, links and blocks.

1.9 Each launching appliance shall, as far as practicable, remain effective under conditions of icing.

1.10 A lifeboat launching appliance shall be capable of recovering the lifeboat with its crew.

1.11 The arrangements of the launching appliance shall be such as to enable safe boarding of the survival craft in accordance with the requirements of regulations 38.4.2, 38.4.3, 41.3.1 and 41.3.2.

2 Launching appliances using falls and a winch

2.1 Falls shall be of rotation-resistant and corrosion-resistant steel wire rope.

2.2 In the case of a multiple drum winch, unless an efficient compensatory device is fitted, the falls shall be so arranged as to wind off the drums at the same rate when lowering, and to wind on to the drums evenly at the same rate when hoisting.

2.3 Every rescue boat launching appliance shall be fitted with a powered winch motor of such capacity that the rescue boat can be raised from the water with its full complement of persons and equipment.

2.4 An efficient hand gear shall be provided for recovery of each survival craft and rescue boat. Hand gear handles or wheels shall not be rotated by moving parts of the winch when the survival craft or rescue boat is being lowered or when it is being hoisted by power.

2.5 Where davit arms are recovered by power, safety devices shall be fitted which will automatically cut off the power before the davit arms reach the stops in order to avoid overstressing the falls or davits, unless the motor is designed to prevent such overstressing.

2.6 The speed at which the survival craft or rescue boat is lowered into the water shall be not less than that obtained from the formula:

$$S = 0.4 + (0.02 \times H)$$

where S = speed of lowering in metres per second

and H = height in metres from davit head to the waterline at the lightest seagoing condition.

2.7 The maximum lowering speed shall be established by the Administration having regard to the design of the survival craft or rescue boat, the protection of its occupants from excessive forces, and the strength of the launching arrangements taking into account inertia forces during an emergency stop. Means shall be incorporated in the appliance to ensure that this speed is not exceeded.

2.8 Every rescue boat launching appliance shall be capable of hoisting the rescue boat when loaded with its full rescue boat complement of persons and equipment at a rate of not less than 0.3 m/s.

2.9 Every launching appliance shall be fitted with brakes capable of stopping the descent of the survival craft or rescue boat and holding it securely when loaded with its full complement of persons and equipment; brake pads shall, where necessary, be protected from water and oil.

2.10 Manual brakes shall be so arranged that the brake is always applied unless the operator, or a mechanism activated by the operator, holds the brake control in the "off" position.

3 *Float-free launching*

Where a survival craft requires a launching appliance and is also designed to float free, the float-free release of the survival craft from its stowed position shall be automatic.

4 *Free-fall launching*

Every free-fall launching appliance using an inclined plane shall, in addition to complying with the applicable requirements of paragraph 1, also comply with the following requirements:

- .1 The launching appliance shall be so arranged that excessive forces are not experienced by the occupants of the survival craft during launching.
- .2 The launching appliance shall be a rigid structure with a ramp angle and length sufficient to ensure that the survival craft effectively clears the ship.
- .3 The launching appliance shall be efficiently protected against corrosion and be so constructed as to prevent incendive friction or impact sparking during the launching of the survival craft.

5 *Evacuation-slide launching and embarkation*

Every evacuation-slide launching appliance shall, in addition to complying with the applicable requirements of paragraph 1, also comply with the following requirements:

- .1 The evacuation-slide shall be capable of being deployed by one person at the embarkation station.
- .2 The evacuation-slide shall be capable of being used in high winds and in a seaway.

6 *Liferaft launching appliances*

Every liferaft launching appliance shall comply with the requirements of paragraphs 1 and 2, except with regard to use of gravity for turning out the appliance, embarkation in the stowed position and recovery of the loaded liferaft. The launching appliance shall be so arranged as to prevent premature release during lowering and shall release the liferaft when waterborne.

7 *Embarkation ladders*

7.1 Handholds shall be provided to ensure a safe passage from the deck to the head of the ladder and vice versa.

7.2 The steps of the ladder shall be:

- .1 made of hardwood, free from knots or other irregularities, smoothly machined and free from sharp edges and splinters, or of suitable material of equivalent properties;
- .2 provided with an efficient non-slip surface either by longitudinal grooving or by the application of an approved non-slip coating;
- .3 not less than 480 mm long, 115 mm wide and 25 mm in depth, excluding any non-slip surface or coating;
- .4 equally spaced not less than 300 mm or more than 380 mm apart and secured in such a manner that they will remain horizontal.

7.3 The side ropes of the ladder shall consist of two uncovered manila ropes not less than 65 mm in circumference on each side. Each rope shall be continuous with no joints below the top step. Other materials may be used provided the dimensions, breaking strain, weathering, stretching and gripping properties are at least equivalent to those of manila rope. All rope ends shall be secured to prevent unravelling.

SECTION VII—OTHER LIFE-SAVING APPLIANCES

Regulation 49

Line-throwing appliances

1 Every line-throwing appliance shall:

- .1 be capable of throwing a line with reasonable accuracy;
- .2 include not less than four projectiles each capable of carrying the line at least 230 m in calm weather;
- .3 include not less than four lines each having a breaking strength of not less than 2 kN;
- .4 have brief instructions or diagrams clearly illustrating the use of the line-throwing appliance.

2 The rocket, in the case of a pistol fired rocket, or the assembly, in the case of an integral rocket and line, shall be contained in a water-resistant casing. In addition, in the case of a pistol-fired rocket, the line and rockets together with the means of ignition shall be stowed in a container which provides protection from the weather.

Regulation 50

General emergency alarm system

The general emergency alarm system shall be capable of sounding the general emergency alarm signal consisting of seven or more short blasts followed by one long blast on the ship's whistle or siren and additionally on an electrically operated bell or klaxon or other equivalent warning system, which shall be powered from the ship's main supply and the emergency source of electrical power required by regulation 11-1/42 or 11-1/43, as appropriate. The system shall be capable of operation from the navigating bridge and, except for the ship's whistle, also from other strategic points. The system shall be audible throughout all the accommodation and normal crew working spaces.

SECTION VIII—MISCELLANEOUS

Regulation 51

Training manual

The training manual, which may comprise several volumes, shall contain instructions and information, in easily understood terms illustrated wherever possible, on the life-saving appliances provided in the ship and on the best methods of survival. Any part of such information may be provided in the form of audio-visual aids in lieu of the manual. The following shall be explained in detail:

- .1 donning of lifejackets and immersion suits, as appropriate;
- .2 muster at the assigned stations;
- .3 boarding, launching, and clearing the survival craft and rescue boats;
- .4 method of launching from within the survival craft;
- .5 release from launching appliances;
- .6 methods and use of devices for protection in launching areas, where appropriate;
- .7 illumination in launching areas;

- .8 use of all survival equipment;
- .9 use of all detection equipment;
- .10 with the assistance of illustrations, the use of radio life-saving appliances;
- .11 use of drogues;
- .12 use of engine and accessories;
- .13 recovery of survival craft and rescue boats including stowage and securing;
- .14 hazards of exposure and the need for warm clothing;
- .15 best use of the survival craft facilities in order to survive;
- .16 methods of retrieval, including the use of helicopter rescue gear (slings, baskets, stretchers), breeches-buoy and shore life-saving apparatus and ship's line-throwing apparatus;
- .17 all other functions contained in the muster list and emergency instructions;
- .18 instructions for emergency repair of the life-saving appliances.

Regulation 52

Instructions for on-board maintenance

Instructions for on-board maintenance of life-saving appliances shall be easily understood, illustrated wherever possible, and, as appropriate, shall include the following for each appliance:

- .1 a checklist for use when carrying out the inspections required by regulation 19.7;
- .2 maintenance and repair instructions;
- .3 schedule of periodic maintenance;
- .4 diagram of lubrication points with the recommended lubricants;
- .5 list of replaceable parts;
- .6 list of sources of spare parts;
- .7 log for records of inspections and maintenance.

Regulation 53

Muster list and emergency instructions

1 The muster list shall specify details of the general emergency alarm signal prescribed by regulation 50 and also action to be taken by crew and passengers when this alarm is sounded. The muster list shall also specify how the order to abandon ship will be given.

2 The muster list shall show the duties assigned to the different members of the crew including:

- .1 closing of the watertight doors, fire doors, valves, scuppers, sidescuttles, skylights, portholes and other similar openings in the ship;
- .2 equipping of the survival craft and other life-saving appliances;
- .3 preparation and launching of survival craft;
- .4 general preparations of other life-saving appliances;
- .5 muster of passengers;
- .6 use of communication equipment;
- .7 manning of fire parties assigned to deal with fires;
- .8 special duties assigned in respect of the use of fire-fighting equipment and installations.

3 The muster list shall specify which officers are assigned to ensure that life-saving and fire appliances are maintained in good condition and are ready for immediate use.

4 The muster list shall specify substitutes for key persons who may become disabled, taking into account that different emergencies may call for different actions.

5 The muster list shall show the duties assigned to members of the crew in relation to passengers in case of emergency. These duties shall include:

- .1 warning the passengers;
- .2 seeing that they are suitably clad and have donned their lifejackets correctly;
- .3 assembling passengers at muster stations;
- .4 keeping order in the passageways and on the stairways and generally controlling the movements of the passengers;
- .5 ensuring that a supply of blankets is taken to the survival craft.

6 The muster list shall be prepared before the ship proceeds to sea. After the muster list has been prepared, if any change takes place in the crew which necessitates an alteration in the muster list, the master shall either revise the list or prepare a new list.

7 The format of the muster list used on passenger ships shall be approved."

Part 4

CHAPTER IV

RADIOTELEGRAPHY AND RADIOTELEPHONY

Regulation 2

Terms and definitions

The following new sub-paragraph is added:

- "(i) 'Emergency position-indicating radio beacon' means a station in the mobile service the emissions of which are intended to facilitate search and rescue operations."

The following new regulations are added:

"Regulation 14-1

Survival craft emergency position-indicating radio beacons

- (a) Survival craft emergency position-indicating radio beacons required by regulation III/6.2.3 to be carried in survival craft shall provide transmissions to enable aircraft to locate the survival craft and may also provide transmissions for alerting purposes.
- (b) Survival craft emergency position-indicating radio beacons shall, at least, be capable of transmitting alternately or simultaneously signals complying with the relevant standards and recommended practices of the International Civil Aviation Organization (ICAO) on the frequencies 121.5 MHz and 243.0 MHz.
- (c) Survival craft emergency position-indicating radio beacons shall:
 - (i) be of a highly visible colour, so designed that they can be used by an unskilled person and so constructed that they may be easily tested and maintained. Batteries shall not require replacement at intervals of less than 12 months, taking into account testing arrangements;
 - (ii) be watertight, capable of floating and being dropped into the water without damage from a height of at least 20 m;
 - (iii) be capable only of manual activation and de-activation;
 - (iv) be portable, lightweight, and compact;
 - (v) be provided with an indication that signals are being emitted;
 - (vi) derive their energy supply from a battery forming an integral part of the device and having sufficient capacity to operate the apparatus for a period of 48 h. The transmission may be intermittent. Determination of the duty cycle should take into account the probability of homing being properly carried out, the need to avoid congestion on the frequencies and the need to comply with the requirements of the International Civil Aviation Organization (ICAO); and
 - (vii) be tested and, if necessary, have their source of energy replaced at intervals not exceeding 12 months.

Regulation 14-2

*Periodic inspection and testing of emergency
position-indicating radio beacons*

Emergency position-indicating radio beacons provided in accordance with regulation III/6.2.3 shall at intervals not exceeding 12 months be inspected, tested and, if necessary, have their source of energy replaced. However, in cases where it appears proper and reasonable, the Administration may extend this period to 17 months.

Regulation 14-3

Two-way radiotelephone apparatus for survival craft

- (a) The apparatus required by regulation 111/6.2.4 shall be so designed that it can be used in an emergency by an unskilled person.
- (b) The apparatus shall be portable and capable of being used for on-board communications.
- (c) The apparatus shall conform to the requirements laid down in the relevant Radio Regulations for equipment used in the maritime mobile service for on-board communications and shall be capable of operation on those channels specified by the Radio Regulations and as required by the Administration. If the apparatus is operating in the VHF band, precautions shall be taken to prevent the inadvertent selection of VHF channel 16 on equipment capable of being operated on that frequency.
- (d) The apparatus shall be operated from a battery of adequate capacity to ensure 4 h operation with a duty cycle of 1 : 9.
- (e) While at sea, the equipment shall be maintained in satisfactory condition, and, whenever necessary, the battery shall be brought to the fully charged condition or replaced."

Part 5

CHAPTER VII

CARRIAGE OF DANGEROUS GOODS

The existing text of chapter VII is replaced by the following:

PART A—CARRIAGE OF DANGEROUS GOODS IN PACKAGED FORM OR IN SOLID FORM IN BULK

Regulation 1

Application

1 Unless expressly provided otherwise, this part applies to dangerous goods, classified under regulation 2 which are carried in packaged form or in solid form in bulk (hereinafter referred to as "dangerous goods"), in all ships to which the present regulations apply and in cargo ships of less than 500 tons gross tonnage.

2 The provisions of this part do not apply to ships' stores and equipment.

3 The carriage of dangerous goods is prohibited except in accordance with the provisions of this part.

4 To supplement the provisions of this part, each Contracting Government shall issue, or cause to be issued, detailed instructions on safe packaging and stowage of dangerous goods which shall include the precautions necessary in relation to other cargo.*

Regulation 2

Classification

Dangerous goods shall be divided into the following classes:

Class 1 — Explosives

Class 2 — Gases: compressed, liquefied or dissolved under pressure

Class 3 — Flammable* liquids

Class 4.1 — Flammable** solids

Class 4.2 — Substances liable to spontaneous combustion

Class 4.3 — Substances which, in contact with water, emit flammable gases

Class 5.1 — Oxidizing substances

Class 5.2 — Organic peroxides

Class 6.1 — Poisonous (toxic) substances

Class 6.2 — Infectious substances

*Reference is made to the International Maritime Dangerous Goods Code (IMDG Code) adopted by the Organization by resolution A.81(IV), and to the relevant sections and the related parts of Appendix B of the Code of Safe Practice for Solid Bulk Cargoes (BC Code) adopted by the Organization by resolution A.434(XI), as have been or may be amended by the Maritime Safety Committee.

**"Flammable" has the same meaning as "inflammable".

Class 7 — Radioactive materials

Class 8 — Corrosives

Class 9 — Miscellaneous dangerous substances, that is any other substance which experience has shown, or may show, to be of such a dangerous character that the provisions of this part shall apply to it.

Regulation 3

Packaging

- 1 The packaging of dangerous goods shall be:
 - .1 well made and in good condition;
 - .2 of such a character that any interior surface with which the contents may come in contact is not dangerously affected by the substance being conveyed; and
 - .3 capable of withstanding the ordinary risks of handling and carriage by sea.
- 2 Where the use of absorbent or cushioning material is customary in the packaging of liquids in receptacles, that material shall be:
 - .1 capable of minimizing the dangers to which the liquid may give rise;
 - .2 so disposed as to prevent movement and ensure that the receptacle remains surrounded; and
 - .3 where reasonably possible, of sufficient quantity to absorb the liquid in the event of breakage of the receptacle.
- 3 Receptacles containing dangerous liquids shall have an ullage at the filling temperature sufficient to allow for the highest temperature during the course of normal carriage.
- 4 Cylinders or receptacles for gases under pressure shall be adequately constructed, tested, maintained and correctly filled.
- 5 Empty uncleaned receptacles which have been used previously for the carriage of dangerous goods shall be subject to the provisions of this part for filled receptacles, unless adequate measures have been taken to nullify any hazard.

Regulation 4

Marking, labelling and placarding

- 1 Packages containing dangerous goods shall be durably marked with the correct technical name; trade names alone shall not be used.
- 2 Packages containing dangerous goods shall be provided with distinctive labels or stencils of the labels, or placards, as appropriate, so as to make clear the dangerous properties of the goods contained therein.
- 3 The method of marking the correct technical name and of affixing labels or applying stencils of labels, or of affixing placards on packages containing dangerous goods, shall be such that this information will still be identifiable on packages surviving at least three months' immersion in the sea. In considering suitable marking, labelling and placarding methods, account shall be taken of the durability of the materials used and of the surface of the package.
- 4 Packages containing dangerous goods shall be so marked and labelled except that:
 - .1 packages containing dangerous goods of a low degree of hazard or packed in limited quantities*; or

*Reference is made to the specific exemptions provided for in the International Maritime Dangerous Goods Code (IMDG Code).

- .2 when special circumstances permit, packages that are stowed and handled in units that are identified by labels or placards*;

may be exempted from labelling requirements.

Regulation 5

Documents

1 In all documents relating to the carriage of dangerous goods by sea where the goods are named, the correct technical name of the goods shall be used (trade names alone shall not be used) and the correct description given in accordance with the classification set out in regulation 2.

2 The shipping documents prepared by the shipper shall include, or be accompanied by, a signed certificate or declaration that the shipment offered for carriage is properly packaged and marked, labelled or placarded, as appropriate, and in proper condition for carriage.

3 Each ship carrying dangerous goods shall have a special list or manifest setting forth, in accordance with the classification set out in regulation 2, the dangerous goods on board and the location thereof. A detailed stowage plan which identifies by class and sets out the location of all dangerous goods on board may be used in place of such special list or manifest.

Regulation 6

Stowage requirements

1 Dangerous goods shall be stowed safely and appropriately in accordance with the nature of the goods. Incompatible goods shall be segregated from one another.

2 Explosives (except ammunition) which present a serious risk shall be stowed in a magazine which shall be kept securely closed while at sea. Such explosives shall be segregated from detonators. Electrical apparatus and cables in any compartment in which explosives are carried shall be so designed and used as to minimize the risk of fire or explosion.

3 Dangerous goods in packaged form which give off dangerous vapours shall be stowed in a mechanically ventilated space or on deck. Dangerous goods in solid form in bulk which give off dangerous vapours shall be stowed in a well-ventilated space.

4 In ships carrying flammable liquids or gases, special precautions shall be taken where necessary against fire or explosion.

5 Substances which are liable to spontaneous heating or combustion shall not be carried unless adequate precautions have been taken to minimize the likelihood of the outbreak of fire.

Regulation 7

Explosives in passenger ships

1 In passenger ships the following explosives only may be carried:

- .1 safety cartridges and safety fuses;
- .2 small quantities of explosives not exceeding 10 kg total net mass;
- .3 distress signals for use in ships or aircraft, if the total mass of such signals does not exceed 1,000 kg;
- .4 except in ships carrying unberthed passengers, fireworks which are unlikely to explode violently.

*Reference is made to the specific exemptions provided for in the International Maritime Dangerous Goods Code (IMDG Code).

2 Notwithstanding the provisions of paragraph 1, additional quantities or types of explosives may be carried in passenger ships in which special safety measures approved by the Administration are taken.

PART B—CONSTRUCTION AND EQUIPMENT OF SHIPS CARRYING DANGEROUS LIQUID CHEMICALS IN BULK

Regulation 8

Definitions

For the purpose of this part, unless expressly provided otherwise:

1 "International Bulk Chemical Code" means the International Code for the Construction and Equipment of Ships Carrying Dangerous Chemicals in Bulk adopted by the Maritime Safety Committee of the Organization by resolution MSC.4(48)', as may be amended by the Organization, provided that such amendments are adopted, brought into force and take effect in accordance with the provisions of article VIII of the present Convention concerning the amendment procedures applicable to the Annex other than chapter I.

2 "Chemical tanker" means a cargo ship constructed or adapted and used for the carriage in bulk of any liquid product listed in chapter 17 of the International Bulk Chemical Code.

3 For the purpose of regulation 9, "ship constructed" means a ship the keel of which is laid or which is at a similar stage of construction.

4 "At a similar stage of construction" means that stage at which:

- .1 construction identifiable with a specific ship begins; and
- .2 assembly of that ship has commenced comprising at least 50 tonnes or 1% of the estimated mass of all structural material, whichever is less.

Regulation 9

Application to chemical tankers

1 Unless expressly provided otherwise, this part applies to chemical tankers constructed on or after 1 July 1986 including those of less than 500 tons gross tonnage. Such tankers shall comply with the requirements of this part in addition to any other applicable requirements of the present regulations.

2 Any chemical tanker, irrespective of the date of construction, which undergoes repairs, alterations, modifications and outfitting related thereto shall continue to comply with at least the requirements previously applicable to the ship. Such a ship, if constructed before 1 July 1986, shall, as a rule, comply with the requirements for a ship constructed on or after that date to at least the same extent as before undergoing such repairs, alterations, modifications or outfitting. Repairs, alterations and modifications of a major character, and outfitting related thereto, shall meet the requirements for a ship constructed on or after 1 July 1986 in so far as the Administration deems reasonable and practicable.

3 A ship, irrespective of the date of construction, which is converted to a chemical tanker shall be treated as a chemical tanker constructed on the date on which such conversion commenced.

¹Treaty Series No. 13. (1998) Cm 3926.

Regulation 10

Requirements for chemical tankers

1 A chemical tanker shall comply with the requirements of the International Bulk Chemical Code and shall, in addition to the requirements of regulations 118, 119, and I/10, as applicable, be surveyed and certified as provided for in that Code. For the purpose of this regulation, the requirements of the Code shall be treated as mandatory.

2 A chemical tanker holding a certificate issued pursuant to the provisions of paragraph 1 shall be subject to the control established in regulation 1/19. For this purpose such certificate shall be treated as a certificate issued under Regulation 1/12 or 1/13.

PART C—CONSTRUCTION AND EQUIPMENT OF SHIPS CARRYING LIQUEFIED GASES IN BULK

Regulation 11

Definitions

For the purpose of this part, unless expressly provided otherwise:

1 "International Gas Carrier Code" means the International Code for the Construction and Equipment of Ships Carrying Liquefied Gases in Bulk as adopted by the Maritime Safety Committee of the Organization by resolution MSC.5(48), as may be amended by the Organization, provided that such amendments are adopted, brought into force and take effect in accordance with the provisions of article VIII of the present Convention concerning the amendment procedures applicable to the Annex other than chapter I.

2 "Gas carrier" means a cargo ship constructed or adapted and used for the carriage in bulk of any liquefied gas or other product listed in chapter 19 of the International Gas Carrier Code.

3 For the purpose of regulation 12, "ship constructed" means a ship the keel of which is laid or which is at a similar stage of construction.

4 "At a similar stage of construction" means the stage at which:

- .1 construction identifiable with a specific ship begins; and
- .2 assembly of that ship has commenced comprising at least 50 tonnes or 1% of the estimated mass of all structural material, whichever is less.

Regulation 12

Application to gas carriers

1 Unless expressly provided otherwise, this part applies to gas carriers constructed on or after 1 July 1986 including those of less than 500 tons gross tonnage. Such gas carriers shall comply with the requirements of this part in addition to any other applicable requirements of the present regulations.

2 Any gas carrier, irrespective of the date of construction, which undergoes repairs, alterations, modifications and outfitting related thereto shall continue to comply with at least the requirements previously applicable to the ship. Such a ship if constructed before 1 July 1986 shall, as a rule, comply with the requirements for a ship constructed on or after that date to at least the same extent as before undergoing such repairs, alterations, modifications or outfitting. Repairs, alterations and modifications of a major character, and outfitting related thereto, shall meet the requirements for a ship constructed on or after 1 July 1986 in so far as the Administration deems reasonable and practicable.

3 A ship, irrespective of the date of construction, which is converted to a gas carrier shall be treated as a gas carrier constructed on the date on which such conversion commenced.

¹Treaty Series No. 15 (1998) Cm 3928.

Regulation 13

Requirements for gas carriers

1 A gas carrier shall comply with the requirements of the International Gas Carrier Code and shall, in addition to the requirements of regulations 1/8, 119 and 1/10, as applicable, be surveyed and certified as provided for in that Code. For the purpose of this regulation, the requirements of the Code shall be treated as mandatory.

2. A gas carrier holding a certificate issued pursuant to the provisions of paragraph 1 shall be subject to the control established in regulation 1/19. For this purpose such certificate shall be treated as a certificate issued under regulation 1/12 or 1/13.

ISBN 0-10-139272-

9 78010 392723



Published by The Stationery Office Limited
and available from:

The Publications Centre
(Mail, telephone and fax orders only)
PO Box 276, London SW8 5DT
General enquiries 0171 873 0011
Order through the Parliamentary Hotline *La-call* 0345 02 34 74
Fax orders 0171 873 8200

The Stationery Office Bookshops
59-60 Holborn Viaduct, London EC1A 2FD
(temporary location until mid-1998)
Fax 0171 831 1326
68-69 Bull Street, Birmingham B4 6AD
0121 236 9696 Fax 0121 236 9699
33 Wine Street, Bristol BS1 2BQ
0117 9264306 Fax 0117 9294515
9 21 Princess Street, Manchester M60 8AS
0161 834 7201 Fax 0161 833 0634
16 Arthur Street, Belfast BT1 4GD
01232 238451 Fax 01232 235401
The Stationery Office Oriel Bookshop,
The Friary, Cardiff CF1 4AA
01222 395548 Fax 01222 384347
71 Lothian Road, Edinburgh EH3 9AZ
0131 228 4181 Fax 0131 622 7017

Accredited Agents
(see Yellow Pages)

and through good booksellers

ISBN 0 10 139272 9